



Click on the highlighted texts for a quick access to the pages 



MODULAR BORING PROGRAM

<u>MODULAR BORING SYSTEM & COUPLING SYSTEM</u>	2
<u>MODULAR BORING SYSTEM ADVANTAGES</u>	3
<u>PRODUCT OVERVIEW</u>	4
<u>MODULAR BORING SYSTEM DESCRIPTION</u>	6
STANDARD BORING HEADS	
<u>ROUGH HEADS 75° APPROACH</u>	8
<u>ROUGH HEADS 90° APPROACH</u>	11
<u>FINISH HEADS 75° APPROACH</u>	14
<u>FINISH HEADS 90° APPROACH</u>	17
<u>MICRO BORING HEADS</u>	20
<u>ISO BORING BARS</u>	21
<u>INDEXABLE BORING BARS FOR A 042 016</u>	22
<u>INDEXABLE STANDARD CARTRIDGES</u>	23
<u>INDEXABLE SPECIAL CARTRIDGES</u>	24
ARBORS FOR BORING HEADS	
<u>MAS BT 403 - BT 30, 40, 45, 50</u>	25
<u>DIN 69871 - AS 30, 40, 45, 50</u>	28
<u>DIN 2080 - OTT 30, 40, 50</u>	31
<u>DIN 69893 - HSK 50, 63, 100</u>	33
<u>DIN 228 - MORSE 2, 3, 4</u>	34
<u>DIN 1806 - MORSE 5</u>	35
<u>DIN 1835 - WELDON 20, 25, 32, 40</u>	36
<u>R8 (BRIDGEPORT)</u>	37
ACCESSORIES	
<u>EXTENSION PIECES</u>	38
<u>COOLANT-FEEDING EXTENSIONS</u>	38
<u>REDUCERS</u>	39
<u>45° CHAMFERING HEADS</u>	39
<u>ADAPTORS</u>	40
SPARE PARTS	
<u>ROUGH BORING HEADS</u>	42
<u>FINISH BORING HEADS</u>	43
<u>LARGE DIAMETER ROUGH BORING HEADS</u>	44
<u>LARGE DIAMETER FINISH BORING HEADS</u>	45
<u>ASSEMBLY SYSTEM FOR LARGE BORING HEADS</u>	46
<u>BORING KITS (BOHRSTAR 54)</u>	48
<u>TOOL PRESETTERS & TOOL LOCKING FIXTURE</u>	50
<u>INSERTS & INSERT SCREWS</u>	52
<u>NOMENCLATURE FOR INSERTS</u>	53
<u>APPLICATION HINTS</u>	55
<u>CUTTING DATA</u>	56
<u>EXAMPLES OF MACHINING</u>	57

MODULAR BORING SYSTEM

Pinzbohr boring system features a wide range of rough and finish boring heads covering diameters from 6 mm up to 500 mm.

There are three types of boring heads:

- 1) Rough boring heads (two inserts) with synchronized adjustment.
- 2) Finish boring heads (one insert) with graduated precision dial readout.
- 3) Micro adjustable boring heads (for small diameters) fitting indexable boring bars with also graduated precision dial readout.

All these boring heads are radially adjustable to machine different diameters.

Different arbor designs are available mating the most popular spindles. Extensions and reducers compliment the modular system to offer a complete flexibility across the range.

The system features a wide range of ISO standard insert pocket choices and indexable cartridges.

The taper screw design allows tools to be changed without removing from the spindle. Main components are manufactured from Nickel-Chrome alloy steel, heat treated to 58-60 HRC.

Precision ground slides ensure accuracy of adjustment throughout the heads working life.



COUPLING SYSTEM

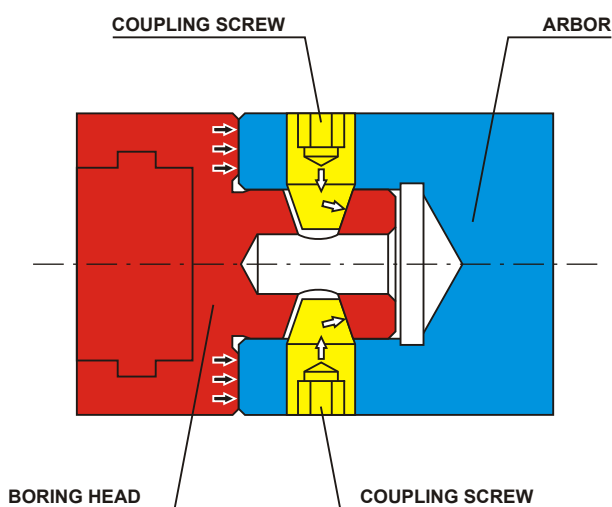

HIGH RIGIDITY

By tightening the two coupling screws, high axial forces are developed in the tapered holes of the arbor. These axial forces preload the contact surface between the flange faces of the coupled components with high axial pressure for ample support against lateral loads. It can also dampen vibrations.

POSITIVE TOOL ORIENTATION

The locating pin guarantees repeat positioning between components at all times.

All arbors, extensions and reducers are shipped complete with coupling screws.

ADVANTAGES

- Practical modular system: different types of boring heads with arbors, extensions, reducers allow price reduction when tooling up the machine.
- Wide range of diameters: 6 mm to 500 mm.
- High accuracy and rigidity: clamping with taper screws (coupling screws).
- Safety-set assembly: designed to prevent damaging the adjustment screw.
- Synchronized adjustment in rough boring heads (no need pre-setting slides with individual adjustment).
- Fine adjustment in finish boring heads: graduated dial and readout precision up to 0.002 mm on diameter.
- Cutting tool selection among a wide variety of insert geometries.
- Main components Nickel-Chrome alloy steel heat treated to 58-60 HRC.
- Ground components to ensure accurate production.



PRODUCT OVERVIEW

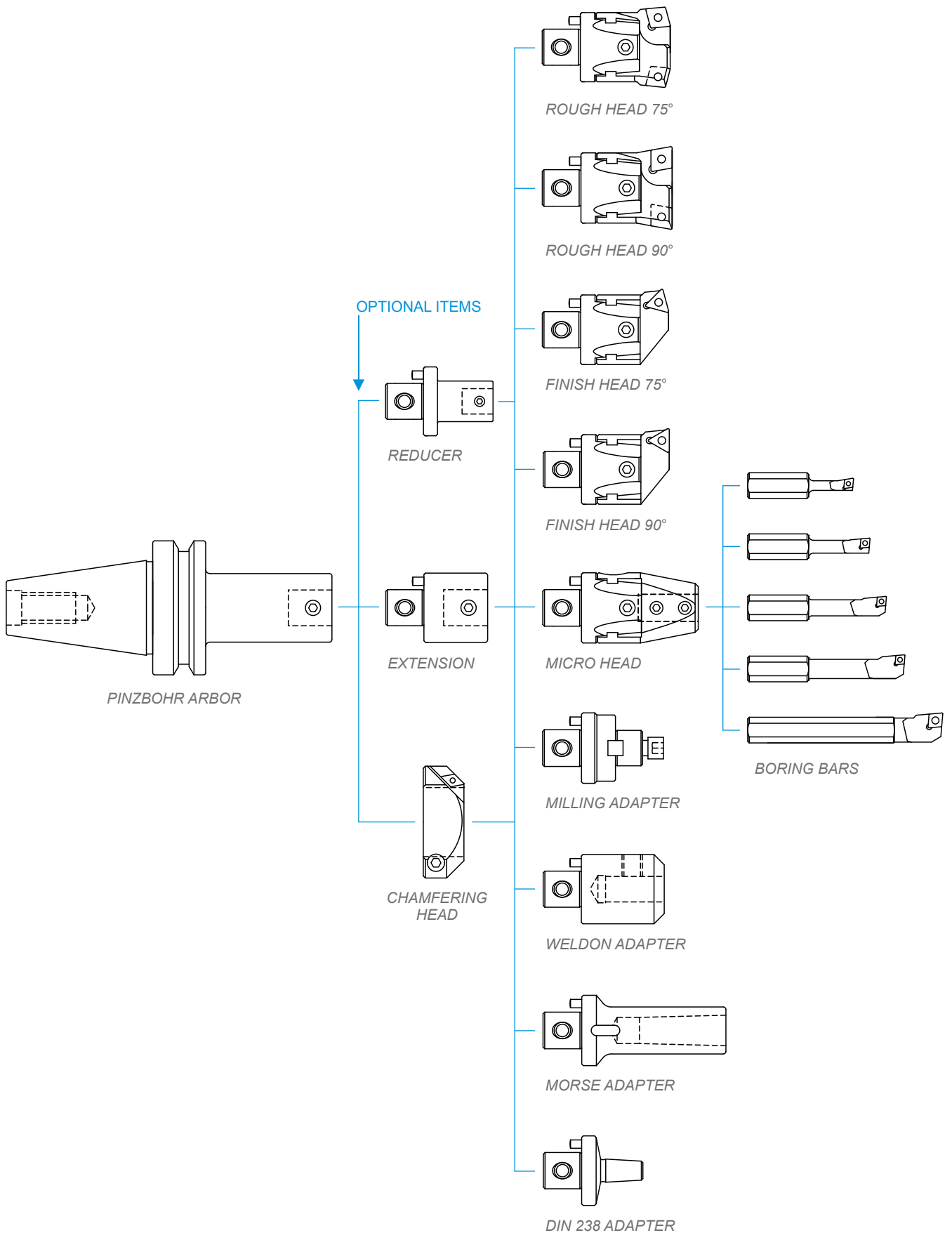

PRODUCT OVERVIEW

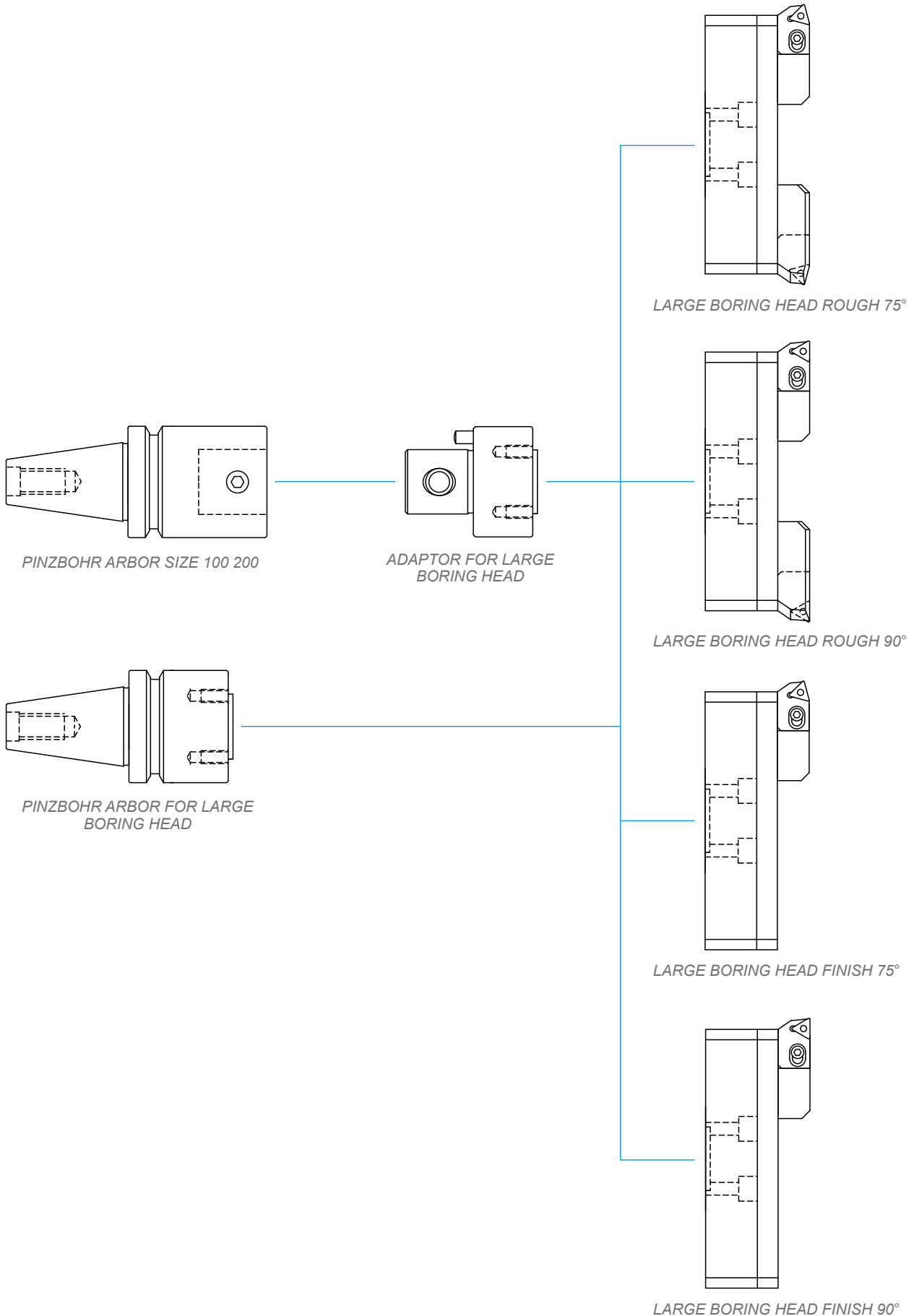

MODULAR BORING SYSTEM DESCRIPTION

ROUGH BORING HEADS

These boring heads with two cutting edges do have synchronized adjustment. This advantage means not to waste time in presetting the two cutting edges for a balanced cut (diameter adjustment can be set in the machine directly with a caliper).

For diameters from 24 mm up to 220 mm, rough boring heads are available in two choices of angle approach: 75° & 90°. And feature various insert pocket geometries to choose.

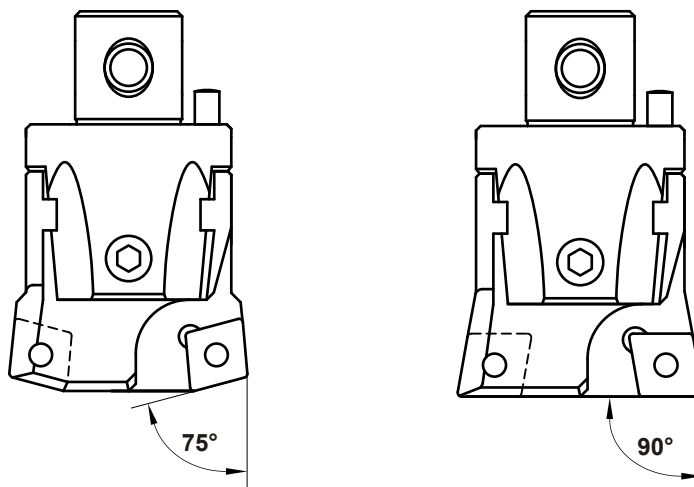

FINISH BORING HEADS

These adjustable boring heads do have a read out precision of 0.002 mm Ø.

For diameters from 24 mm up to 220 mm, finish boring heads are available in two choices of angle approach: 75° & 90°. And feature various insert pocket geometries to choose.

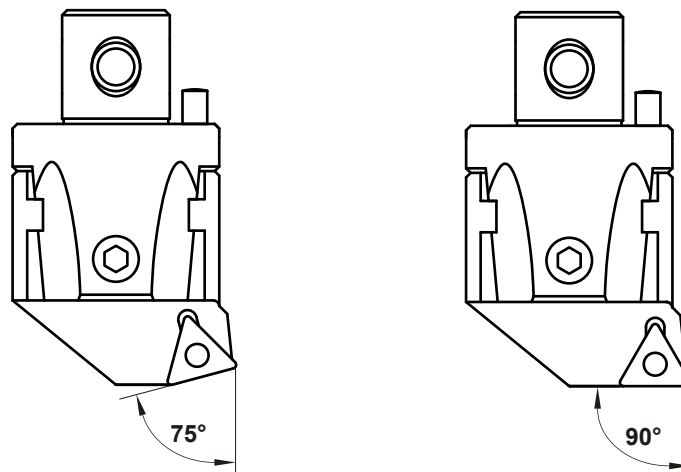

MODULAR BORING SYSTEM DESCRIPTION

MICRO BORING HEADS

MICRO boring heads are used in combination with indexable ISO boring bars; these units can produce bores down to 6 mm diameter and up to 38 mm diameter. MICRO boring heads fit the standard Pinzbohr arbors size 27, 32 and 42 (recommended in extra short execution).

Graduated dial and readout precision of 0.002 mm \varnothing .

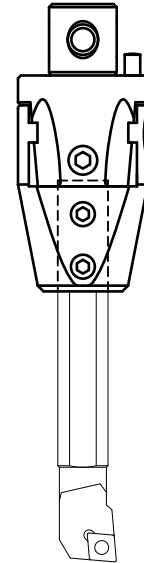

LARGE DIAMETER BORING HEADS

These boring heads, either rough and finish do have graduated dial and readout precision of 0.002 mm \varnothing and a diameter range that goes from 220 mm up to 500 mm.

Four (4) facing coupling screws do the assembly of large diameter boring heads to its holder.

By using *ADT 100 050* adaptor it is possible to assemble large diameter boring heads to the standard size *100 200* Pinzbohr arbors to allow the use of longer arbors for deep boring applications.

ROUGH BORING HEADS

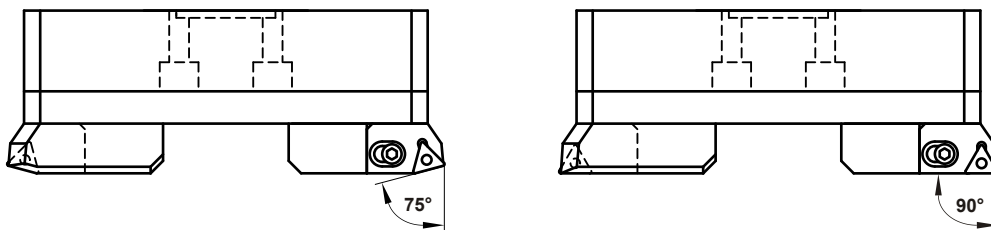

FINISH BORING HEADS

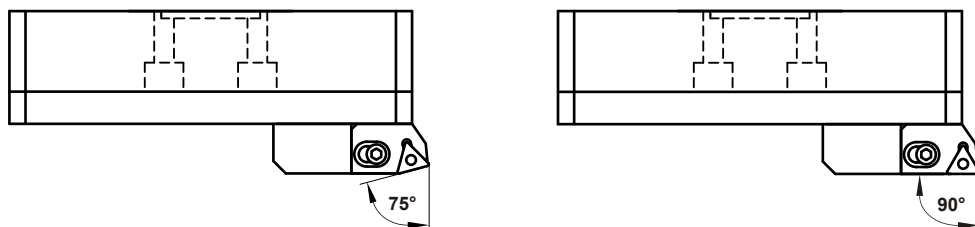

ROUGH HEADS 75° APPROACH

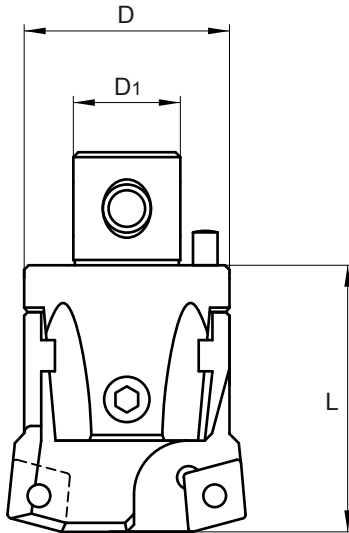

INTEGRAL POCKET TYPE HEADS SYNCHRONIZED ADJUSTMENT



SIZE	Bore Range		Dimension			Product Number	Insert	Torx Screw	Kg.	Adj. Key		
	Min	Max	øD	øD1	L					Torx Key	Locking Key	
22	24	30	22	12	34	D 02275 400	CC□□ 0602□□	TT 400	0.100	HK 020	TK 08	HK 030
27	29	40	27	15	42	D 02775 401	CC□□ 0803□□	TT 401	0.170	HK 020	TK 10	HK 040
	29	40	27	15	42	D 02775 409	CC□□ 09T3□□	TT 409	0.170	HK 020	TK 15	HK 040
32	39	50	32	20	45	D 03275 401	CC□□ 0803□□	TT 401	0.270	HK 025	TK 10	HK 040
	39	50	32	20	45	D 03275 409	CC□□ 09T3□□	TT 409	0.270	HK 025	TK 15	HK 040
42	49	65	42	24	56	D 04275 300	TC□□ 16T3□□	TT 300	0.550	HK 030	TK 15	HK 050
	49	65	42	24	56	D 04275 402	CC□□ 1204□□	TT 402	0.550	HK 030	TK 20	HK 050
	53	65	42	24	56	D 04275 402 N	CN□□ 1204□□ R	TT 402 N	0.550	HK 030	HK 025	HK 050
54	63	82	54	28	66	D 05475 300	TC□□ 16T3□□	TT 300	1.080	HK 030	TK 15	HK 060
	63	82	54	28	66	D 05475 402	CC□□ 1204□□	TT 402	1.080	HK 030	TK 20	HK 060
	63	82	54	28	66	D 05475 402 N	CN□□ 1204□□ R	TT 402 N	1.080	HK 030	HK 025	HK 060

☐ NOMENCLATURE FOR INSERT SELECTION IN PAGE 53

☐ TORX SCREW DETAILS IN PAGE 52

ROUGH HEADS 75° APPROACH

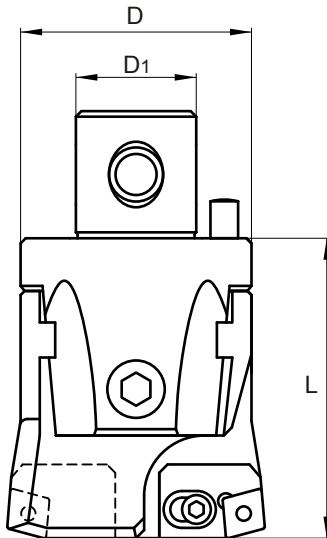

CARTRIDGE TYPE HEADS SYNCHRONIZED ADJUSTMENT



SIZE	Bore Range		Dimension			Product Number	Cartridge	Torx Screw	Kg.	Adj. Key		
	Min	Max	øD	øD1	L					Torx Key	Locking Key	
68	80	102	68	36	86	D 06875 300	2CT 75 300	TT 409	2.180	HK 040	TK 15	HK 080
	80	102	68	36	86	D 06875 402	2CT 75 402	TT 116	2.180	HK 040	TK 20	HK 080
	80	102	68	36	86	D 06875 402 N	2CT 75 402 N	TT 402 N	2.180	HK 040	HK 025	HK 080
85	100	125	85	50	100	D 08575 300	3CT 75 300	TT 300	4.150	HK 050	TK 15	HK 080
	100	125	85	50	100	D 08575 402	3CT 75 402	TT 402	4.150	HK 050	TK 20	HK 080
	100	125	85	50	100	D 08575 402 N	3CT 75 402 N	TT 402 N	4.150	HK 050	HK 025	HK 080
100	125	160	110	60	100	D 10075 300	3CT 75 300	TT 300	6.580	HK 050	TK 15	HK 080
	125	160	110	60	100	D 10075 402	3CT 75 402	TT 402	6.580	HK 050	TK 20	HK 080
	125	160	110	60	100	D 10075 402 N	3CT 75 402 N	TT 402 N	6.580	HK 050	HK 025	HK 080
200	160	220	145	60	100	D 20075 300	3CT 75 300	TT 300	8.950	HK 050	TK 15	HK 080
	160	220	145	60	100	D 20075 402	3CT 75 402	TT 402	8.950	HK 050	TK 20	HK 080
	160	220	145	60	100	D 20075 402 N	3CT 75 402 N	TT 402 N	8.950	HK 050	HK 025	HK 080

FULL CARTRIDGE INFORMATION (INCLUDING INSERT SIZE) IN PAGE 23

ROUGH HEADS 75° APPROACH

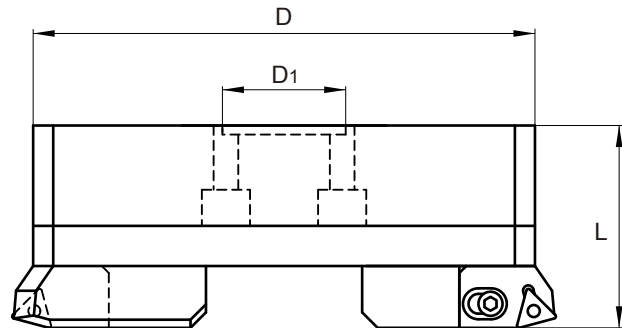

ADJUSTING ACCURACY 0.002 mm Ø



LARGE DIAMETER CARTRIDGE TYPE HEADS SYNCHRONIZED ADJUSTMENT



SIZE	Bore Range		Dimension			Product Number	Cartridge	Torx Screw	Kg.	Adjustment		
	Min	Max	øD	øD1	L					Adj. Key	Torx Key	Locking Key
300	220	320	202	60	90	D 30075 300	3CT 75 300	TT 300	9.370	HK 050	TK 15	HK 040
	220	320	202	60	90	D 30075 402	3CT 75 402	TT 402	9.370	HK 050	TK 20	HK 040
	220	320	202	60	90	D 30075 402 N	3CT 75 402 N	TT 402 N	9.370	HK 050	HK 025	HK 040
400	290	400	272	60	90	D 40075 300	3CT 75 300	TT 300	12.980	HK 050	TK 15	HK 040
	290	400	272	60	90	D 40075 402	3CT 75 402	TT 402	12.980	HK 050	TK 20	HK 040
	290	400	272	60	90	D 40075 402 N	3CT 75 402 N	TT 402 N	12.980	HK 050	HK 025	HK 040
500	370	500	352	60	90	D 50075 300	3CT 75 300	TT 300	16.740	HK 050	TK 15	HK 040
	370	500	352	60	90	D 50075 402	3CT 75 402	TT 402	16.740	HK 050	TK 20	HK 040
	370	500	352	60	90	D 50075 402 N	3CT 75 402 N	TT 402 N	16.740	HK 050	HK 025	HK 040

FULL CARTRIDGE INFORMATION (INCLUDING INSERT SIZE) IN PAGE 23

ARBOR ASSEMBLY SYSTEM FOR LARGE BORING HEADS IN PAGES 46 AND 47

ROUGH HEADS 90° APPROACH

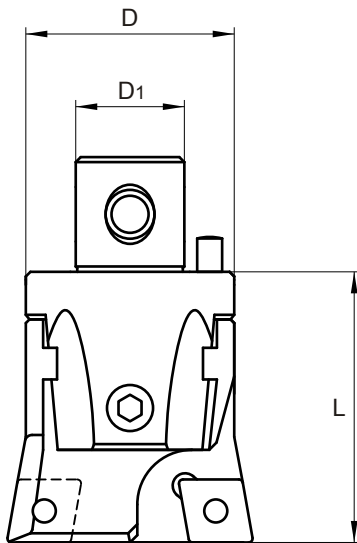

INTEGRAL POCKET TYPE HEADS SYNCHRONIZED ADJUSTMENT



SIZE	Bore Range		Dimension			Product Number	Insert	Torx Screw	Kg.	Adj. Key		
	Min	Max	øD	øD1	L					Torx Key	Locking Key	
22	24	30	22	12	34	D 02290 400	CC□□ 0602□□	TT 400	0.100	HK 020	TK 08	HK 030
27	29	40	27	15	42	D 02790 401	CC□□ 0803□□	TT 401	0.170	HK 020	TK 10	HK 040
	29	40	27	15	42	D 02790 409	CC□□ 09T3□□	TT 409	0.170	HK 020	TK 15	HK 040
32	39	50	32	20	45	D 03290 401	CC□□ 0803□□	TT 401	0.270	HK 025	TK 10	HK 040
	39	50	32	20	45	D 03290 409	CC□□ 09T3□□	TT 409	0.270	HK 025	TK 15	HK 040
42	49	65	42	24	56	D 04290 300	TC□□ 16T3□□	TT 300	0.550	HK 030	TK 15	HK 050
	49	65	42	24	56	D 04290 402	CC□□ 1204□□	TT 402	0.550	HK 030	TK 20	HK 050
	53	65	42	24	56	D 04290 402 N	CN□□ 1204□□ L	TT 402 N	0.550	HK 030	HK 025	HK 050
54	63	82	54	28	66	D 05490 300	TC□□ 16T3□□	TT 300	1.080	HK 030	TK 15	HK 060
	63	82	54	28	66	D 05490 402	CC□□ 1204□□	TT 402	1.080	HK 030	TK 20	HK 060
	63	82	54	28	66	D 05490 402 N	CN□□ 1204□□ L	TT 402 N	1.080	HK 030	HK 025	HK 060

☐ NOMENCLATURE FOR INSERT SELECTION IN PAGE 53

☐ TORX SCREW DETAILS IN PAGE 52

ROUGH HEADS 90° APPROACH

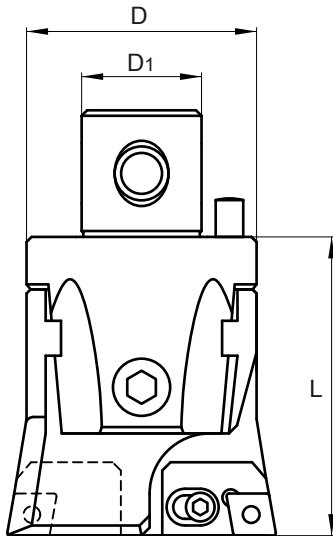

CARTRIDGE TYPE HEADS SYNCHRONIZED ADJUSTMENT



SIZE	Bore Range		Dimension			Product Number	Cartridge	Torx Screw	Kg.	Adj. Key		
	Min	Max	øD	øD1	L					Torx Key	Locking Key	
68	80	102	68	36	86	D 06890 300	2CT 90 300	TT 409	2.180	HK 040	TK 15	HK 080
	80	102	68	36	86	D 06890 402	2CT 90 402	TT 116	2.180	HK 040	TK 20	HK 080
	80	102	68	36	86	D 06890 402 N	2CT 90 402 N	TT 402 N	2.180	HK 040	HK 025	HK 080
85	100	125	85	50	100	D 08590 300	3CT 90 300	TT 300	4.150	HK 050	TK 15	HK 080
	100	125	85	50	100	D 08590 402	3CT 90 402	TT 402	4.150	HK 050	TK 20	HK 080
	100	125	85	50	100	D 08590 402 N	3CT 90 402 N	TT 402 N	4.150	HK 050	HK 025	HK 080
100	125	160	110	60	100	D 10090 300	3CT 90 300	TT 300	6.580	HK 050	TK 15	HK 080
	125	160	110	60	100	D 10090 402	3CT 90 402	TT 402	6.580	HK 050	TK 20	HK 080
	125	160	110	60	100	D 10090 402 N	3CT 90 402 N	TT 402 N	6.580	HK 050	HK 025	HK 080
200	160	220	145	60	100	D 20090 300	3CT 90 300	TT 300	8.950	HK 050	TK 15	HK 080
	160	220	145	60	100	D 20090 402	3CT 90 402	TT 402	8.950	HK 050	TK 20	HK 080
	160	220	145	60	100	D 20090 402 N	3CT 90 402 N	TT 402 N	8.950	HK 050	HK 025	HK 080

FULL CARTRIDGE INFORMATION (INCLUDING INSERT SIZE) IN PAGE 23

ROUGH HEADS 90° APPROACH

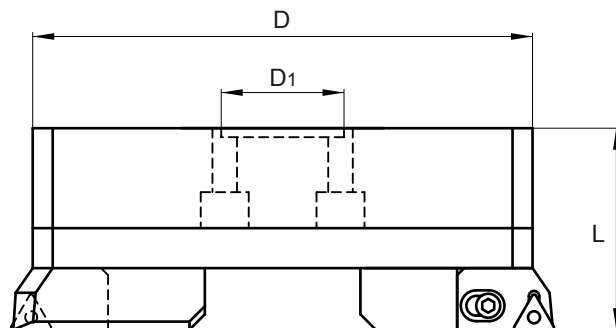

ADJUSTING ACCURACY 0.002 mm Ø



LARGE DIAMETER CARTRIDGE TYPE HEADS SYNCHRONIZED ADJUSTMENT



SIZE	Bore Range		Dimension			Product Number	Cartridge	Torx Screw	Kg.	Adj. Key		
	Min	Max	øD	øD1	L					Torx Key	Locking Key	
300	220	320	202	60	90	D 30090 300	3CT 90 300	TT 300	9.370	HK 050	TK 15	HK 040
	220	320	202	60	90	D 30090 402	3CT 90 402	TT 402	9.370	HK 050	TK 20	HK 040
	220	320	202	60	90	D 30090 402 N	3CT 90 402 N	TT 402 N	9.370	HK 050	HK 025	HK 040
400	290	400	272	60	90	D 40090 300	3CT 90 300	TT 300	12.980	HK 050	TK 15	HK 040
	290	400	272	60	90	D 40090 402	3CT 90 402	TT 402	12.980	HK 050	TK 20	HK 040
	290	400	272	60	90	D 40090 402 N	3CT 90 402 N	TT 402 N	12.980	HK 050	HK 025	HK 040
500	370	500	352	60	90	D 50090 300	3CT 90 300	TT 300	16.740	HK 050	TK 15	HK 040
	370	500	352	60	90	D 50090 402	3CT 90 402	TT 402	16.740	HK 050	TK 20	HK 040
	370	500	352	60	90	D 50090 402 N	3CT 90 402 N	TT 402 N	16.740	HK 050	HK 025	HK 040

📄 FULL CARTRIDGE INFORMATION (INCLUDING INSERT SIZE) IN PAGE 23

🏠 ARBOR ASSEMBLY SYSTEM FOR LARGE BORING HEADS IN PAGES 46 AND 47

FINISH HEADS 75° APPROACH

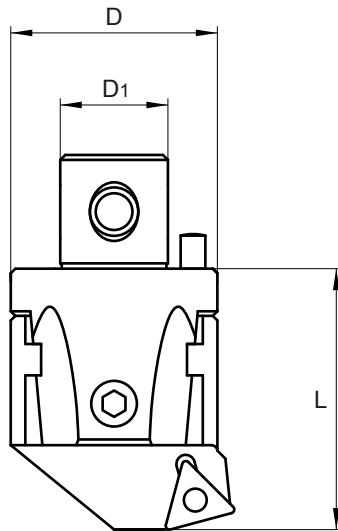

INTEGRAL POCKET TYPE HEADS ADJUSTING ACCURACY 0.002 mm Ø



SIZE	Bore Range		Dimension			Product Number	Insert	Torx Screw	Kg.	Adj. Key		
	Min	Max	øD	øD1	L					Torx Key	Locking Key	
22	24	30	22	12	34	A 02275 310	TP □□ 0902□□	TT 400	0.100	HK 020	TK 08	HK 030
	24	30	22	12	34	A 02275 400	CC□□ 0602□□	TT 400	0.100	HK 020	TK 08	HK 030
27	29	40	27	15	42	A 02775 310	TP □□ 0902□□	TT 400	0.160	HK 020	TK 08	HK 040
	29	40	27	15	42	A 02775 401	CC□□ 0803□□	TT 401	0.160	HK 020	TK 10	HK 040
	29	40	27	15	42	A 02775 409	CC□□ 09T3□□	TT 409	0.160	HK 020	TK 15	HK 040
32	39	50	32	20	45	A 03275 310	TP □□ 0902□□	TT 400	0.250	HK 025	TK 08	HK 040
	39	50	32	20	45	A 03275 401	CC□□ 0803□□	TT 401	0.250	HK 025	TK 10	HK 040
	39	50	32	20	45	A 03275 409	CC□□ 09T3□□	TT 409	0.250	HK 025	TK 15	HK 040
42	49	65	42	24	56	A 04275 300	TC□□ 16T3□□	TT 300	0.510	HK 030	TK 15	HK 050
	49	65	42	24	56	A 04275 311	TP □□ 1103□□	TT 401	0.510	HK 030	TK 10	HK 050
54	63	82	54	28	66	A 05475 300	TC□□ 16T3□□	TT 300	1.020	HK 030	TK 15	HK 060
	63	82	54	28	66	A 05475 311	TP □□ 1103□□	TT 401	1.020	HK 030	TK 10	HK 060

📄 NOMENCLATURE FOR INSERT SELECTION IN PAGE 53

🔑 TORX SCREW DETAILS IN PAGE 52

FINISH HEADS 75° APPROACH

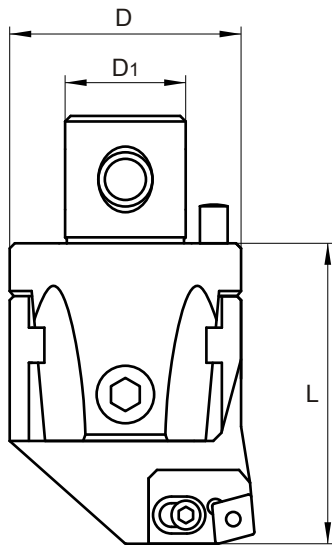

CARTRIDGE TYPE HEADS ADJUSTING ACCURACY 0.002 mm Ø



SIZE	Bore Range		Dimension			Product Number	Cartridge	Torx Screw	Kg.	Key		
	Min	Max	øD	øD1	L					Adj. Key	Torx Key	Locking Key
68	80	102	68	36	86	A 06875 300	2CT 75 300	TT 409	2.050	HK 050	TK 15	HK 080
	80	102	68	36	86	A 06875 311	2CT 75 311	TT 401	2.050	HK 050	TK 10	HK 080
	80	102	68	36	86	A 06875 402	2CT 75 402	TT 116	2.050	HK 050	TK 20	HK 080
	80	102	68	36	86	A 06875 402 N	2CT 75 402 N	TT 402 N	2.050	HK 050	HK 025	HK 080
85	100	125	85	50	100	A 08575 300	3CT 75 300	TT 300	3.930	HK 060	TK 15	HK 080
	100	125	85	50	100	A 08575 311	3CT 75 311	TT 401	3.930	HK 060	TK 10	HK 080
	100	125	85	50	100	A 08575 402	3CT 75 402	TT 402	3.930	HK 060	TK 20	HK 080
	100	125	85	50	100	A 08575 402 N	3CT 75 402 N	TT 402 N	3.930	HK 060	HK 025	HK 080
100	125	160	110	60	100	A 10075 300	3CT 75 300	TT 300	6.250	HK 060	TK 15	HK 080
	125	160	110	60	100	A 10075 311	3CT 75 311	TT 401	6.250	HK 060	TK 10	HK 080
	125	160	110	60	100	A 10075 402	3CT 75 402	TT 402	6.250	HK 060	TK 20	HK 080
	125	160	110	60	100	A 10075 402 N	3CT 75 402 N	TT 402 N	6.250	HK 060	HK 025	HK 080
200	160	220	145	60	100	A 20075 300	3CT 75 300	TT 300	8.330	HK 060	TK 15	HK 080
	160	220	145	60	100	A 20075 311	3CT 75 311	TT 401	8.330	HK 060	TK 10	HK 080
	160	220	145	60	100	A 20075 402	3CT 75 402	TT 402	8.330	HK 060	TK 20	HK 080
	160	220	145	60	100	A 20075 402 N	3CT 75 402 N	TT 402 N	8.330	HK 060	HK 025	HK 080

📄 FULL CARTRIDGE INFORMATION (INCLUDING INSERT SIZE) IN PAGE 23

FINISH HEADS 75° APPROACH

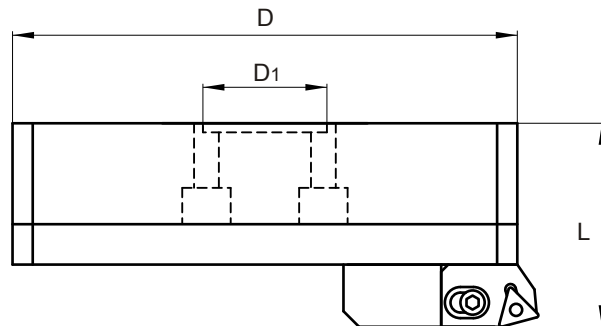

LARGE DIAMETER CARTRIDGE TYPE HEADS ADJUSTING ACCURACY 0.002 mm Ø



SIZE	Bore Range		Dimension			Product Number	Cartridge	Torx Screw	Kg.	Key		
	Min	Max	øD	øD1	L					Adj. Key	Torx Key	Locking Key
300	220	320	202	60	90	A 30075 300	3CT 75 300	TT 300	8.750	HK 050	TK 15	HK 040
	220	320	202	60	90	A 30075 311	3CT 75 311	TT 401	8.750	HK 050	TK 10	HK 040
	220	320	202	60	90	A 30075 402	3CT 75 402	TT 402	8.750	HK 050	TK 20	HK 040
	220	320	202	60	90	A 30075 402 N	3CT 75 402 N	TT 402 N	8.750	HK 050	HK 025	HK 040
400	290	400	272	60	90	A 40075 300	3CT 75 300	TT 300	12.200	HK 050	TK 15	HK 040
	290	400	272	60	90	A 40075 311	3CT 75 311	TT 401	12.200	HK 050	TK 10	HK 040
	290	400	272	60	90	A 40075 402	3CT 75 402	TT 402	12.200	HK 050	TK 20	HK 040
	290	400	272	60	90	A 40075 402 N	3CT 75 402 N	TT 402 N	12.200	HK 050	HK 025	HK 040
500	370	500	352	60	90	A 50075 300	3CT 75 300	TT 300	16.310	HK 050	TK 15	HK 040
	370	500	352	60	90	A 50075 311	3CT 75 311	TT 401	16.310	HK 050	TK 10	HK 040
	370	500	352	60	90	A 50075 402	3CT 75 402	TT 402	16.310	HK 050	TK 20	HK 040
	370	500	352	60	90	A 50075 402 N	3CT 75 402 N	TT 402 N	16.310	HK 050	HK 025	HK 040

📄 [FULL CARTRIDGE INFORMATION \(INCLUDING INSERT SIZE\) IN PAGE 23](#)

📄 [ARBOR ASSEMBLY SYSTEM FOR LARGE BORING HEADS IN PAGES 46 AND 47](#)

FINISH HEADS 90° APPROACH

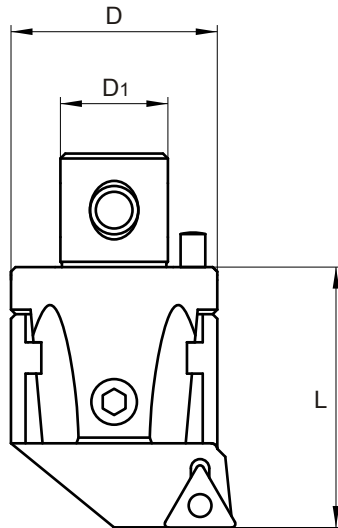

INTEGRAL POCKET TYPE HEADS ADJUSTING ACCURACY 0.002 mm Ø



SIZE	Bore Range		Dimension			Product Number	Insert	Torx Screw	Kg.	Adj. Key Torx Key Locking Key		
	Min	Max	ØD	ØD1	L					HK	TK	HK
22	24	30	22	12	34	A 02290 310	TP□□ 0902□□	TT 400	0.100	HK 020	TK 08	HK 030
	24	30	22	12	34	A 02290 400	CC□□ 0602□□	TT 400	0.100	HK 020	TK 08	HK 030
27	29	40	27	15	42	A 02790 310	TP□□ 0902□□	TT 400	0.160	HK 020	TK 08	HK 040
	29	40	27	15	42	A 02790 401	CC□□ 0803□□	TT 401	0.160	HK 020	TK 10	HK 040
	29	40	27	15	42	A 02790 409	CC□□ 09T3□□	TT 409	0.160	HK 020	TK 15	HK 040
32	39	50	32	20	45	A 03290 300	TC□□ 16T3□□	TT 409	0.250	HK 025	TK 15	HK 040
	39	50	32	20	45	A 03290 310	TP□□ 0902□□	TT 400	0.250	HK 025	TK 08	HK 040
	39	50	32	20	45	A 03290 401	CC□□ 0803□□	TT 401	0.250	HK 025	TK 10	HK 040
	39	50	32	20	45	A 03290 409	CC□□ 09T3□□	TT 409	0.250	HK 025	TK 15	HK 040
42	49	65	42	24	56	A 04290 300	TC□□ 16T3□□	TT 300	0.510	HK 030	TK 15	HK 050
	49	65	42	24	56	A 04290 311	TP□□ 1103□□	TT 401	0.510	HK 030	TK 10	HK 050
	49	65	42	24	56	A 04290 402	CC□□ 1204□□	TT 402	0.510	HK 030	TK 20	HK 050
	53	65	42	24	56	A 04290 402 N	CN□□ 1204□□ L	TT 402 N	0.510	HK 030	HK 025	HK 050
54	63	82	54	28	66	A 05490 300	TC□□ 16T3□□	TT 300	1.020	HK 030	TK 15	HK 060
	63	82	54	28	66	A 05490 311	TP□□ 1103□□	TT 401	1.020	HK 030	TK 10	HK 060
	63	82	54	28	66	A 05490 402	CC□□ 1204□□	TT 402	1.020	HK 030	TK 20	HK 060
	63	82	54	28	66	A 05490 402 N	CN□□ 1204□□ L	TT 402 N	1.020	HK 030	HK 025	HK 060

📄 NOMENCLATURE FOR INSERT SELECTION IN PAGE 53

🔧 TORX SCREW DETAILS IN PAGE 52

FINISH HEADS 90° APPROACH

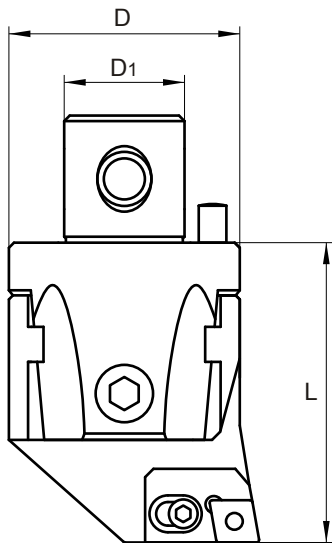

CARTRIDGE TYPE HEADS ADJUSTING ACCURACY 0.002 mm Ø



SIZE	Bore Range		Dimension			Product Number	Cartridge	Torx Screw	Kg.	Adjusting Accuracy		
	Min	Max	øD	øD1	L					Adj. Key	Torx Key	Locking Key
68	80	102	68	36	86	A 06890 300	2CT 90 300	TT 409	2.050	HK 050	TK 15	HK 080
	80	102	68	36	86	A 06890 311	2CT 90 311	TT 401	2.050	HK 050	TK 10	HK 080
	80	102	68	36	86	A 06890 402	2CT 90 402	TT 116	2.050	HK 050	TK 20	HK 080
	80	102	68	36	86	A 06890 402 N	2CT 90 402 N	TT 402 N	2.050	HK 050	HK 025	HK 080
85	100	125	85	50	100	A 08590 300	3CT 90 300	TT 300	3.930	HK 060	TK 15	HK 080
	100	125	85	50	100	A 08590 311	3CT 90 311	TT 401	3.930	HK 060	TK 10	HK 080
	100	125	85	50	100	A 08590 402	3CT 90 402	TT 402	3.930	HK 060	TK 20	HK 080
	100	125	85	50	100	A 08590 402 N	3CT 90 402 N	TT 402 N	3.930	HK 060	HK 025	HK 080
100	125	160	110	60	100	A 10090 300	3CT 90 300	TT 300	6.250	HK 060	TK 15	HK 080
	125	160	110	60	100	A 10090 311	3CT 90 311	TT 401	6.250	HK 060	TK 10	HK 080
	125	160	110	60	100	A 10090 402	3CT 90 402	TT 402	6.250	HK 060	TK 20	HK 080
	125	160	110	60	100	A 10090 402 N	3CT 90 402 N	TT 402 N	6.250	HK 060	HK 025	HK 080
200	160	220	145	60	100	A 20090 300	3CT 90 300	TT 300	8.330	HK 060	TK 15	HK 080
	160	220	145	60	100	A 20090 311	3CT 90 311	TT 401	8.330	HK 060	TK 10	HK 080
	160	220	145	60	100	A 20090 402	3CT 90 402	TT 402	8.330	HK 060	TK 20	HK 080
	160	220	145	60	100	A 20090 402 N	3CT 90 402 N	TT 402 N	8.330	HK 060	HK 025	HK 080

FULL CARTRIDGE INFORMATION (INCLUDING INSERT SIZE) IN PAGE 23

FINISH HEADS 90° APPROACH

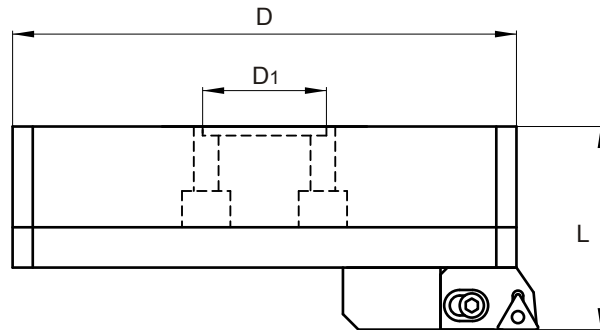

LARGE DIAMETER CARTRIDGE TYPE HEADS ADJUSTING ACCURACY 0.002 mm Ø



SIZE	Bore Range		Dimension			Product Number	Cartridge	Torx Screw	Kg.	Key		
	Min	Max	øD	øD1	L					Adj. Key	Torx Key	Locking Key
300	220	320	202	60	90	A 30090 300	3CT 90 300	TT 300	8.750	HK 050	TK 15	HK 040
	220	320	202	60	90	A 30090 311	3CT 90 311	TT 401	8.750	HK 050	TK 10	HK 040
	220	320	202	60	90	A 30090 402	3CT 90 402	TT 402	8.750	HK 050	TK 20	HK 040
	220	320	202	60	90	A 30090 402 N	3CT 90 402 N	TT 402 N	8.750	HK 050	HK 025	HK 040
400	290	400	272	60	90	A 40090 300	3CT 90 300	TT 300	12.200	HK 050	TK 15	HK 040
	290	400	272	60	90	A 40090 311	3CT 90 311	TT 401	12.200	HK 050	TK 10	HK 040
	290	400	272	60	90	A 40090 402	3CT 90 402	TT 402	12.200	HK 050	TK 20	HK 040
	290	400	272	60	90	A 40090 402 N	3CT 90 402 N	TT 402 N	12.200	HK 050	HK 025	HK 040
500	370	500	352	60	90	A 50090 300	3CT 90 300	TT 300	16.310	HK 050	TK 15	HK 040
	370	500	352	60	90	A 50090 311	3CT 90 311	TT 401	16.310	HK 050	TK 10	HK 040
	370	500	352	60	90	A 50090 402	3CT 90 402	TT 402	16.310	HK 050	TK 20	HK 040
	370	500	352	60	90	A 50090 402 N	3CT 90 402 N	TT 402 N	16.310	HK 050	HK 025	HK 040

FULL CARTRIDGE INFORMATION (INCLUDING INSERT SIZE) IN PAGE 23

ARBOR ASSEMBLY SYSTEM FOR LARGE BORING HEADS IN PAGES 46 AND 47

MICRO BORING HEADS

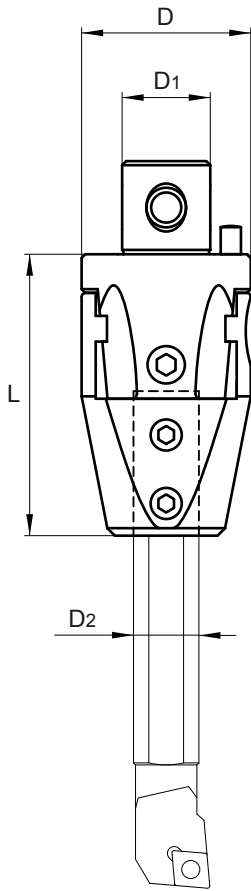

HEADS FOR ISO BORING BARS ADJUSTING ACCURACY 0.002 mm Ø



SIZE	Bore Range		Dimension				Product Number	Kg.	Adj. Key / Locking Key	
	Min	Max	øD	øD1	øD2	L			Adj. Key	Locking Key
27	8	20	27	15	6	50	A 027 006	0.210	HK 020	HK 040
27	10	21	27	15	8	50	A 027 008	0.200	HK 020	HK 040
32	10	21	32	20	8	58	A 032 008	0.330	HK 025	HK 040
32	13	25	32	20	10	58	A 032 010	0.330	HK 025	HK 040
42	13	29	42	24	10	70	A 042 010	0.660	HK 030	HK 050
42	16	34	42	24	12	70	A 042 012	0.660	HK 030	HK 050
42	20	38	42	24	16	70	A 042 016	0.630	HK 030	HK 050

ISO BORING BARS

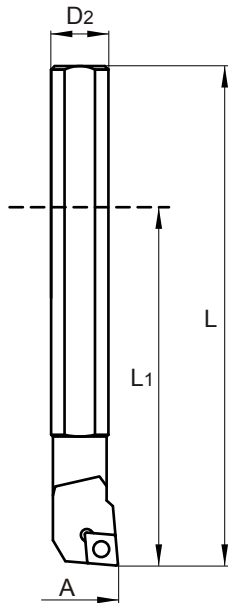

STEEL SHANK BORING BARS

Dimension				ISO Boring bar	Insert	Torx Screw	Torx Key
øD2	øA	L	L1				
6	8	70	46	S06E SELPR 04	EP□□ 0401□□ L	TT 102	TK 06
6	8	70	46	S06E SELPR 05	EP□□ 0502□□	TT 106	TK 07
8	10	80	50	S08F SCLCR 06	CC□□ 0602□□	TT 110	TK 08
10	13	90	54	S10G SCLCR 06	CC□□ 0602□□	TT 400	TK 08
12	16	100	64	S12H SCLCR 06	CC□□ 0602□□	TT 400	TK 08
16	20	110	74	S16J SCLCR 09	CC□□ 09T3□□	TT 409	TK 15
16	20	110	74	S16J STFCR 09	TC□□ 0902□□	TT 108	TK 07
16	20	110	74	S16J STFCR 16	TC□□ 16T3□□	TT 409	TK 15

CARBIDE SHANK BORING BARS

Dimension				ISO Boring bar	Insert	Torx Screw	Torx Key
øD2	øA	L	L1				
6	8	80	56	C06F SELPR 04	EP□□ 0401□□ L	TT 102	TK 06
8	10	90	60	C08G SCLCR 06	CC□□ 0602□□	TT 110	TK 08
10	13	110	74	C10J SCLCR 06	CC□□ 0602□□	TT 400	TK 08
12	16	125	89	C12K SCLCR 06	CC□□ 0602□□	TT 400	TK 08
16	20	140	104	C16L SCLCR 09	CC□□ 09T3□□	TT 409	TK 15

☐ NOMENCLATURE FOR INSERT SELECTION IN PAGE 53

☐ TORX SCREW DETAILS IN PAGE 52

INDEXABLE BORING BARS FOR A 042 016

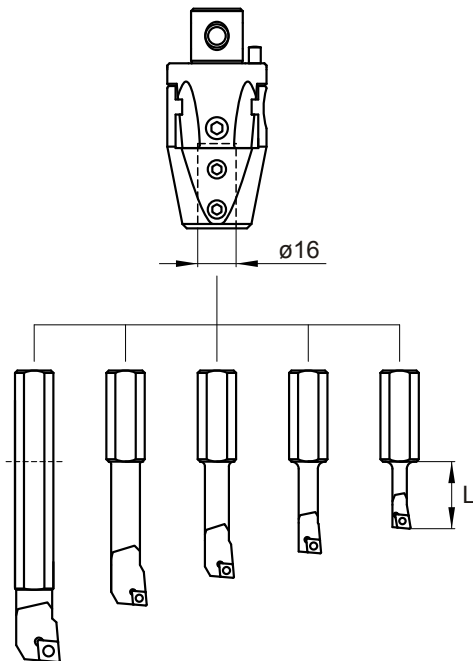

RHOMBIC INSERT

Bore Range		L	Product Number	Insert	Torx Screw	Torx Key
Min	Max					
6	24	20	S05/16 SELPR 04	EP□□ 0401□□ L	TT 100	TK 06
8	26	25	S06/16 SELPR 04	EP□□ 0401□□ L	TT 102	TK 06
8	26	25	S06/16 SELPR 05	EP□□ 0502□□	TT 106	TK 07
10	28	35	S08/16 SCLCR 06	CC□□ 0602□□	TT 110	TK 08
13	31	45	S10/16 SCLCR 06	CC□□ 0602□□	TT 400	TK 08
16	34	57	S12/16 SCLCR 06	CC□□ 0602□□	TT 400	TK 08
20	38	73	S16/16 SCLCR 09	CC□□ 09T3□□	TT 409	TK 15

TRIANGULAR INSERT

Bore Range		L	Product Number	Insert	Torx Screw	Torx Key
Min	Max					
8	26	25	S06/16 STFCR 06	TC□□ 06T1□□	TT 104	TK 06
10	28	35	S08/16 STFCR 06	TC□□ 06T1□□	TT 104	TK 06
13	31	45	S10/16 STFCR 09	TC□□ 0902□□	TT 108	TK 07
16	34	57	S12/16 STFCR 09	TC□□ 0902□□	TT 108	TK 07
20	38	73	S16/16 STFCR 09	TC□□ 0902□□	TT 108	TK 07
20	38	73	S16/16 STFCR 16	TC□□ 16T3□□	TT 409	TK 15

☐ NOMENCLATURE FOR INSERT SELECTION IN PAGE 53

☐ TORX SCREW DETAILS IN PAGE 52

INDEXABLE STANDARD CARTRIDGES

SYMETRICAL BORING

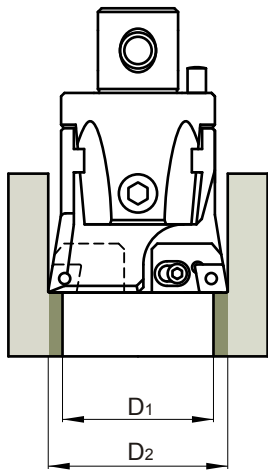

2CT □□ □□ + 2CT □□ □□
or
3CT □□ □□ + 3CT □□ □□

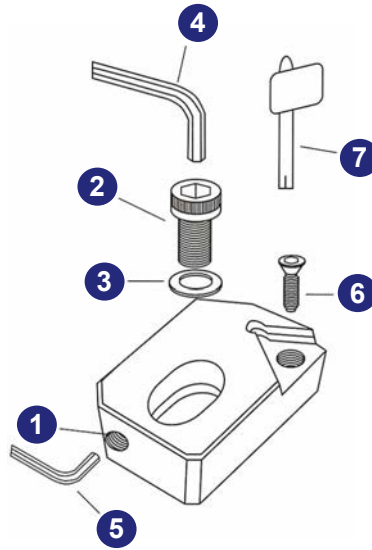

STAGGERED BORING

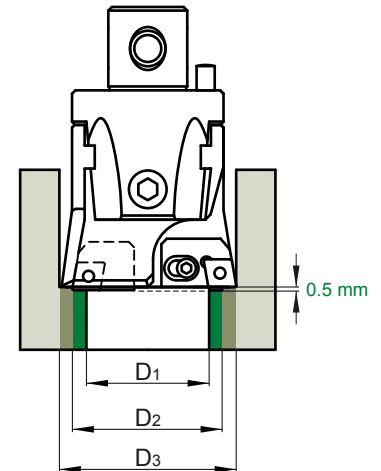

2CT □□ □□ S + 2CT □□ □□
or
3CT □□ □□ S + 3CT □□ □□

STAGGERED CARTRIDGES IN NEXT PAGE

TYPE 90 300

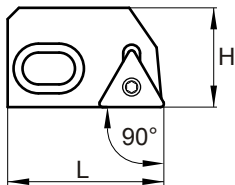

TYPE 75 300

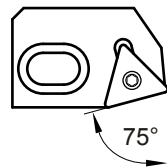

TYPE 90 402

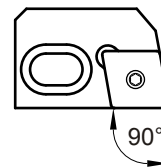

TYPE 75 402

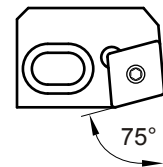

Product Number	Dimension		Kg.	Insert	1	2	3	4	5	6	7
	H	L									
2CT 75 300	22.5	35	0.050	TC□□ 16T3□□	D 068 29	A 068 26	D 068 28	HK 050	HK 020	TT 409	TK 15
2CT 75 311	22.5	35	0.050	TP□□ 1103□□	D 068 29	A 068 26	D 068 28	HK 050	HK 020	TT 401	TK 10
2CT 75 402	22.5	35	0.050	CC□□ 1204□□	D 068 29	A 068 26	D 068 28	HK 050	HK 020	TT 116	TK 20
2CT 75 402 N	22.5	35	0.070	CN□□ 1204□□ R	D 068 29	A 068 26	D 068 28	HK 050	HK 020	TT 402 N	HK 025
2CT 90 300	22.5	35	0.050	TC□□ 16T3□□	D 068 29	A 068 26	D 068 28	HK 050	HK 020	TT 409	TK 15
2CT 90 311	22.5	35	0.050	TP□□ 1103□□	D 068 29	A 068 26	D 068 28	HK 050	HK 020	TT 401	TK 10
2CT 90 402	22.5	35	0.050	CC□□ 1204□□	D 068 29	A 068 26	D 068 28	HK 050	HK 020	TT 116	TK 20
2CT 90 402 N	22.5	35	0.070	CN□□ 1204□□ L	D 068 29	A 068 26	D 068 28	HK 050	HK 020	TT 402 N	HK 025
3CT 75 300	28	39	0.100	TC□□ 16T3□□	D 085 29	D 085 27	D 068 28	HK 050	HK 030	TT 300	TK 15
3CT 75 311	28	39	0.100	TP□□ 1103□□	D 085 29	D 085 27	D 068 28	HK 050	HK 030	TT 401	TK 10
3CT 75 402	28	39	0.100	CC□□ 1204□□	D 085 29	D 085 27	D 068 28	HK 050	HK 030	TT 402	TK 20
3CT 75 402 N	28	39	0.120	CN□□ 1204□□ R	D 085 29	D 085 27	D 068 28	HK 050	HK 030	TT 402 N	HK 025
3CT 90 300	28	39	0.100	TC□□ 16T3□□	D 085 29	D 085 27	D 068 28	HK 050	HK 030	TT 300	TK 15
3CT 90 311	28	39	0.100	TP□□ 1103□□	D 085 29	D 085 27	D 068 28	HK 050	HK 030	TT 401	TK 10
3CT 90 402	28	39	0.100	CC□□ 1204□□	D 085 29	D 085 27	D 068 28	HK 050	HK 030	TT 402	TK 20
3CT 90 402 N	28	39	0.120	CN□□ 1204□□ L	D 085 29	D 085 27	D 068 28	HK 050	HK 030	TT 402 N	HK 025

☐ NOMENCLATURE FOR INSERT SELECTION IN PAGE 53

☐ TORX SCREW DETAILS IN PAGE 52

INDEXABLE SPECIAL CARTRIDGES

TYPE GR 300

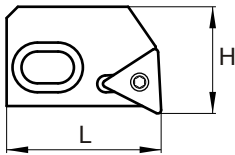

TYPE GR 411

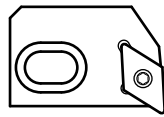

TYPE 30 300

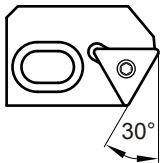

TYPE 45 300

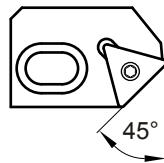

TYPE 85 502

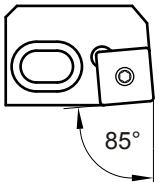

TYPE W06 / W08

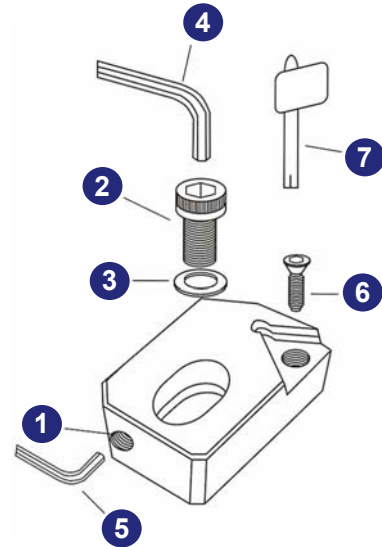
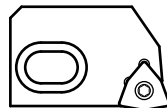

Product Number	Dimension		Kg.	Insert	1	2	3	4	5	6	7
	H	L									
2CT GR 300	25	36	0.050	TC □□ 16T3□□	D 068 29	A 068 26	D 068 28	HK 050	HK 020	TT 409	TK 15
2CT GR 411	25	36	0.050	DC □□ 11T3□□	D 068 29	A 068 26	D 068 28	HK 050	HK 020	TT 409	TK 15
2CT 30 300	22.5	35	0.050	TC □□ 16T3□□	D 068 29	A 068 26	D 068 28	HK 050	HK 020	TT 409	TK 15
2CT 45 300	22.5	35	0.050	TC □□ 16T3□□	D 068 29	A 068 26	D 068 28	HK 050	HK 020	TT 409	TK 15
2CT 85 502	22.5	35	0.050	SC □□ 1204□□	D 068 29	A 068 26	D 068 28	HK 050	HK 020	TT 116	TK 20
2CT 90 W06	23.5	35	0.050	WC □□ 06T3□□	D 068 29	A 068 26	D 068 28	HK 050	HK 020	TT 112	TK 09
2CT 90 W06 S	24	33	0.050	WC □□ 06T3□□	D 068 29	A 068 26	D 068 28	HK 050	HK 020	TT 112	TK 09
2CT 90 300 S	23	33	0.050	TC □□ 16T3□□	D 068 29	A 068 26	D 068 28	HK 050	HK 020	TT 409	TK 15
2CT 90 402 S	23	33	0.050	CC □□ 1204□□	D 068 29	A 068 26	D 068 28	HK 050	HK 020	TT 116	TK 20
2CT 90 402 N S	23	33	0.070	CN □□ 1204□□ L	D 068 29	A 068 26	D 068 28	HK 050	HK 020	TT 402 N	HK 025
3CT GR 300	30	40	0.100	TC □□ 16T3□□	D 085 29	D 085 27	D 068 28	HK 050	HK 030	TT 300	TK 15
3CT GR 411	30	40	0.100	DC □□ 11T3□□	D 085 29	D 085 27	D 068 28	HK 050	HK 030	TT 300	TK 15
3CT 30 300	28	39	0.100	TC □□ 16T3□□	D 085 29	D 085 27	D 068 28	HK 050	HK 030	TT 300	TK 15
3CT 45 300	28	39	0.100	TC □□ 16T3□□	D 085 29	D 085 27	D 068 28	HK 050	HK 030	TT 300	TK 15
3CT 85 502	28	39	0.100	SC □□ 1204□□	D 085 29	D 085 27	D 068 28	HK 050	HK 030	TT 402	TK 20
3CT 90 W08	29	39	0.100	WC □□ 0804□□	D 085 29	D 085 27	D 068 28	HK 050	HK 030	TT 114	TK 15
3CT 90 W08 S	29.5	37	0.100	WC □□ 0804□□	D 085 29	D 085 27	D 068 28	HK 050	HK 030	TT 114	TK 15
3CT 90 300 S	28.5	37	0.100	TC □□ 16T3□□	D 085 29	D 085 27	D 068 28	HK 050	HK 030	TT 300	TK 15
3CT 90 402 S	28.5	37	0.100	CC □□ 1204□□	D 085 29	D 085 27	D 068 28	HK 050	HK 030	TT 402	TK 20
3CT 90 402 N S	28.5	37	0.120	CN □□ 1204□□ L	D 085 29	D 085 27	D 068 28	HK 050	HK 030	TT 402 N	HK 025

☐ NOMENCLATURE FOR INSERT SELECTION IN PAGE 53

🔩 TORX SCREW DETAILS IN PAGE 52

ARBORS FOR BORING HEADS

MAS BT 403

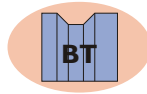

ISO 30

SIZE	Dimension					Product Number	Kg.	Coupling Screw
	øD	øD1	L	L1	PM			
22	22	12	125	91	100	BT 330 022 100	0.650	TC 022
27	27	15	77	35	55	BT 330 027 055	0.480	TC 027
	27	15	125	83	100	BT 330 027 100	0.700	TC 027
32	32	20	83	38	60	BT 330 032 060	0.490	TC 032
	32	20	125	80	100	BT 330 032 100	0.760	TC 032
42	42	24	100	44	75	BT 330 042 075	0.590	TC 042



ISO 40

SIZE	Dimension					Product Number	Kg.	Coupling Screw
	øD	øD1	L	L1	PM			
22	22	12	80	46	50	BT 340 022 050	1.100	TC 022
	22	12	110	76	80	BT 340 022 080	1.200	TC 022
	22	12	130	96	100	BT 340 022 100	1.250	TC 022
27	27	15	82	40	55	BT 340 027 055	1.100	TC 027
	27	15	130	88	100	BT 340 027 100	1.310	TC 027
	27	15	160	118	130	BT 340 027 130	1.450	TC 027
32	32	20	88	43	60	BT 340 032 060	1.140	TC 032
	32	20	130	85	100	BT 340 032 100	1.390	TC 032
	32	20	160	115	130	BT 340 032 130	1.580	TC 032
42	42	24	104	48	75	BT 340 042 075	1.180	TC 042
	42	24	190	134	160	BT 340 042 160	2.120	TC 042
	42	24	230	174	200	BT 340 042 200	2.600	TC 042
54	54	28	120	54	90	BT 340 054 090	1.350	TC 054
	54	28	190	124	160	BT 340 054 160	2.610	TC 054
	54	28	230	164	200	BT 340 054 200	3.370	TC 054
68	68	36	181	95	160	BT 340 068 160	2.600	TC 068
	68	36	221	135	200	BT 340 068 200	3.760	TC 068
85	85	50	220	120	200	BT 340 085 200	4.210	TC 068
100 200	100	60	220	120	200	BT 340 100 200	4.910	TC 100

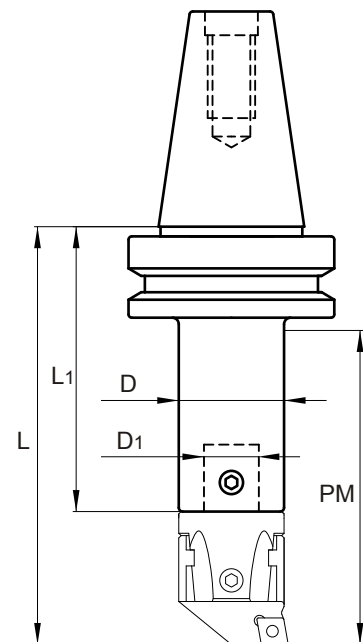

ARBORS FOR BORING HEADS

MAS BT 403

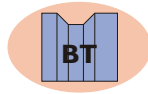

ISO 45 (UPON REQUEST)

SIZE	Dimension					Product Number	Kg.	Coupling Screw
	øD	øD1	L	L1	PM			
22	22	12	116	82	80	BT 345 022 080	2.550	TC 022
	22	12	136	102	100	BT 345 022 100	2.610	TC 022
27	27	15	88	46	55	BT 345 027 055	2.550	TC 027
	27	15	136	94	100	BT 345 027 100	2.750	TC 027
	27	15	166	124	130	BT 345 027 130	2.800	TC 027
32	32	20	94	49	60	BT 345 032 060	2.550	TC 032
	32	20	166	121	130	BT 345 032 130	2.950	TC 032
	32	20	196	151	160	BT 345 032 160	3.200	TC 032
42	42	24	110	54	75	BT 345 042 075	2.650	TC 042
	42	24	196	140	160	BT 345 042 160	3.500	TC 042
	42	24	236	180	200	BT 345 042 200	4.000	TC 042
54	54	28	123	57	90	BT 345 054 090	2.850	TC 054
	54	28	196	130	160	BT 345 054 160	4.100	TC 054
	54	28	236	170	200	BT 345 054 200	4.800	TC 054
68	68	36	237	151	200	BT 345 068 200	5.550	TC 068
	68	36	297	211	260	BT 345 068 260	7.250	TC 068
85	85	50	236	136	200	BT 345 085 200	6.100	TC 068
	85	50	296	196	260	BT 345 085 260	8.850	TC 068
	85	50	356	256	320	BT 345 085 320	11.650	TC 068

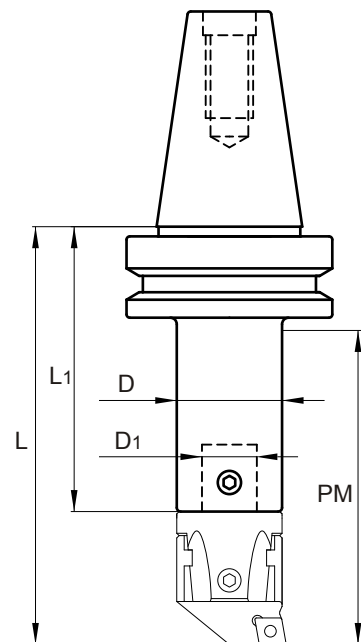

ARBORS FOR BORING HEADS

MAS BT 403

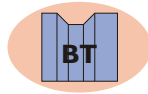

ISO 50

SIZE	Dimension					Product Number	Kg.	Coupling Screw
	øD	øD1	L	L1	PM			
22	22	12	121	87	80	BT 350 022 080	3.980	TC 022
	22	12	141	107	100	BT 350 022 100	4.050	TC 022
27	27	15	93	51	55	BT 350 027 055	3.870	TC 027
	27	15	141	99	100	BT 350 027 100	4.080	TC 027
	27	15	171	129	130	BT 350 027 130	4.220	TC 027
32	32	20	99	54	60	BT 350 032 060	3.870	TC 032
	32	20	171	126	130	BT 350 032 130	4.340	TC 032
	32	20	201	156	160	BT 350 032 160	4.520	TC 032
42	42	24	115	59	75	BT 350 042 075	3.930	TC 042
	42	24	201	145	160	BT 350 042 160	4.900	TC 042
	42	24	241	185	200	BT 350 042 200	5.400	TC 042
54	54	28	131	65	90	BT 350 054 090	4.110	TC 054
	54	28	201	135	160	BT 350 054 160	5.400	TC 054
	54	28	241	175	200	BT 350 054 200	6.100	TC 054
68	68	36	154	68	115	BT 350 068 115	4.280	TC 068
	68	36	242	156	200	BT 350 068 200	6.820	TC 068
	68	36	302	216	260	BT 350 068 260	8.600	TC 068
85	85	50	242	142	200	BT 350 085 200	7.520	TC 068
	85	50	302	202	260	BT 350 085 260	10.270	TC 068
	85	50	362	262	320	BT 350 085 320	13.080	TC 068
100 200	100	60	195	95	170	BT 350 100 170	5.780	TC 100
	100	60	302	202	260	BT 350 100 260	12.460	TC 100
	100	60	362	262	320	BT 350 100 320	16.080	TC 100
300 400 500	100	60	160	70	125	* BT 550 160	6.010	TF 100

* SEE PAGES 46 AND 47: ASSEMBLY SYSTEM FOR LARGE BORING HEADS

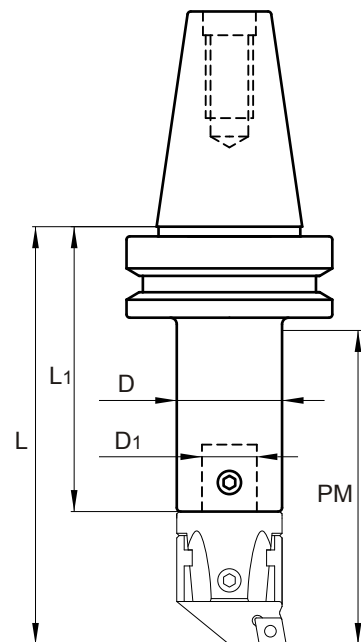

ARBORS FOR BORING HEADS

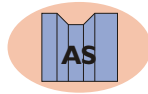
DIN 69871

ISO 30

SIZE	Dimension					Product Number	Kg.	Coupling Screw
	øD	øD1	L	L1	PM			
22	22	12	138	104	100	AS 330 022 100	0.700	TC 022
27	27	15	90	48	55	AS 330 027 055	0.560	TC 027
	27	15	138	96	100	AS 330 027 100	0.740	TC 027
32	32	20	96	51	60	AS 330 032 060	0.580	TC 032
	32	20	138	93	100	AS 330 032 100	0.800	TC 032

ISO 40

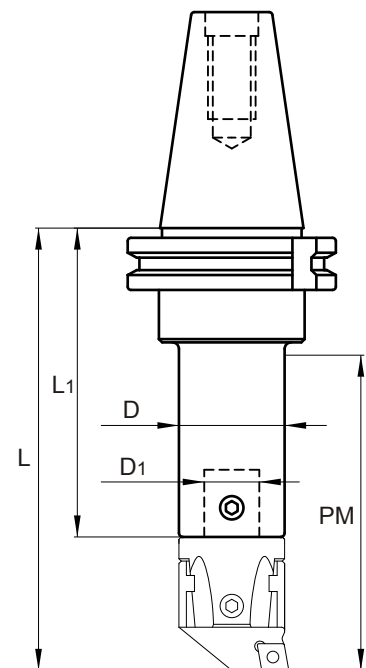
SIZE	Dimension					Product Number	Kg.	Coupling Screw
	øD	øD1	L	L1	PM			
22	22	12	118	84	80	AS 340 022 080	1.230	TC 022
	22	12	138	104	100	AS 340 022 100	1.300	TC 022
27	27	15	90	48	55	AS 340 027 055	1.130	TC 027
	27	15	138	96	100	AS 340 027 100	1.350	TC 027
	27	15	168	126	130	AS 340 027 130	1.490	TC 027
32	32	20	96	51	60	AS 340 032 060	1.140	TC 032
	32	20	138	93	100	AS 340 032 100	1.400	TC 032
	32	20	168	123	130	AS 340 032 130	1.590	TC 032
42	42	24	112	56	75	AS 340 042 075	1.200	TC 042
	42	24	182	126	160	AS 340 042 160	1.980	TC 042
	42	24	222	166	200	AS 340 042 200	2.460	TC 042
54	54	28	142	76	120	AS 340 054 120	1.630	TC 054
	54	28	182	116	160	AS 340 054 160	2.360	TC 054
	54	28	222	156	200	AS 340 054 200	3.110	TC 054
68	68	36	183	97	160	AS 340 068 160	2.480	TC 068
	68	36	223	137	200	AS 340 068 200	3.630	TC 068
85	85	50	224	124	200	AS 340 085 200	4.240	TC 068
¹⁰⁰ / ₂₀₀	100	60	224	124	200	AS 340 100 200	5.160	TC 100

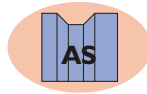

ARBORS FOR BORING HEADS

DIN 69871

ISO 45 (UPON REQUEST)

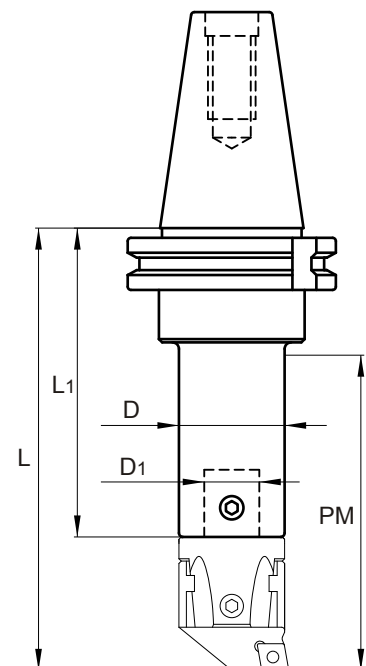
SIZE	Dimension					Product Number	Kg.	Coupling Screw
	øD	øD1	L	L1	PM			
22	22	12	118	84	80	AS 345 022 080	2.250	TC 022
	22	12	138	104	100	AS 345 022 100	2.350	TC 022
27	27	15	90	48	55	AS 345 027 055	2.010	TC 027
	27	15	138	96	100	AS 345 027 100	2.400	TC 027
	27	15	168	126	130	AS 345 027 130	2.600	TC 027
32	32	20	96	51	60	AS 345 032 060	1.800	TC 032
	32	20	168	123	130	AS 345 032 130	2.850	TC 032
	32	20	198	153	160	AS 345 032 160	3.100	TC 032
42	42	24	112	56	75	AS 345 042 075	2.100	TC 042
	42	24	198	142	160	AS 345 042 160	3.000	TC 042
	42	24	238	182	200	AS 345 042 200	3.300	TC 042
54	54	28	125	59	90	AS 345 054 090	2.400	TC 054
	54	28	182	116	160	AS 345 054 160	3.900	TC 054
	54	28	222	156	200	AS 345 054 200	4.650	TC 054
68	68	36	223	137	200	AS 345 068 200	4.800	TC 068
	68	36	283	197	260	AS 345 068 260	6.650	TC 068
85	85	50	224	124	200	AS 345 085 200	5.400	TC 068
	85	50	284	184	260	AS 345 085 260	8.150	TC 068
	85	50	344	244	320	AS 345 085 320	8.900	TC 068

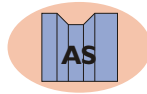

ARBORS FOR BORING HEADS

DIN 69871

ISO 50

SIZE	Dimension					Product Number	Kg.	Coupling Screw
	øD	øD1	L	L1	PM			
22	22	12	118	84	80	AS 350 022 080	3.450	TC 022
	22	12	138	104	100	AS 350 022 100	3.500	TC 022
27	27	15	90	48	55	AS 350 027 055	3.300	TC 027
	27	15	138	96	100	AS 350 027 100	3.550	TC 027
	27	15	168	126	130	AS 350 027 130	3.680	TC 027
32	32	20	96	51	60	AS 350 032 060	3.310	TC 032
	32	20	168	123	130	AS 350 032 130	3.790	TC 032
	32	20	198	153	160	AS 350 032 160	3.980	TC 032
42	42	24	112	56	75	AS 350 042 075	3.390	TC 042
	42	24	198	142	160	AS 350 042 160	4.360	TC 042
	42	24	238	182	200	AS 350 042 200	4.860	TC 042
54	54	28	128	62	90	AS 350 054 090	3.570	TC 054
	54	28	198	132	160	AS 350 054 160	4.850	TC 054
	54	28	238	172	200	AS 350 054 200	5.570	TC 054
68	68	36	151	65	115	AS 350 068 115	3.740	TC 068
	68	36	223	137	200	AS 350 068 200	5.800	TC 068
	68	36	283	197	260	AS 350 068 260	7.600	TC 068
85	85	50	224	124	200	AS 350 085 200	6.300	TC 068
	85	50	284	184	260	AS 350 085 260	9.040	TC 068
	85	50	344	244	320	AS 350 085 320	11.700	TC 068
100 200	100	60	214	114	190	AS 350 100 190	6.600	TC 100
	100	60	284	184	260	AS 350 100 260	11.000	TC 100
	100	60	344	244	320	AS 350 100 320	14.660	TC 100
300 400 500	100	60	160	70	125	* AS 550 160	5.650	TF 100

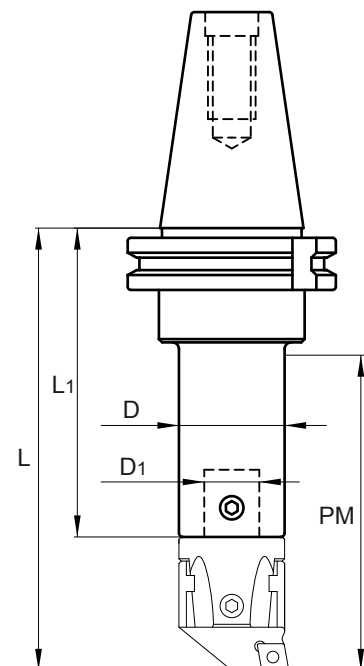
* SEE PAGES 46 AND 47: ASSEMBLY SYSTEM FOR LARGE BORING HEADS



ARBORS FOR BORING HEADS

DIN 2080

OTT

ISO 30

SIZE	Dimension					Product Number	Kg.	Coupling Screw
	øD	øD1	L	L1	PM			
22	22	12	113	79	100	OTT 330 022 100	0.570	TC 022
27	27	15	65	23	55	OTT 330 027 055	0.490	TC 027
	27	15	113	71	100	OTT 330 027 100	0.630	TC 027
32	32	20	71	26	60	OTT 330 032 060	0.420	TC 032
	32	20	113	68	100	OTT 330 032 100	0.680	TC 032
42	42	24	87	31	75	OTT 330 042 075	0.510	TC 042

ISO 40

SIZE	Dimension					Product Number	Kg.	Coupling Screw
	øD	øD1	L	L1	PM			
22	22	12	95	61	80	OTT 340 022 080	0.980	TC 022
	22	12	115	81	100	OTT 340 022 100	1.050	TC 022
27	27	15	67	25	55	OTT 340 027 055	0.900	TC 027
	27	15	115	73	100	OTT 340 027 100	1.110	TC 027
	27	15	145	103	130	OTT 340 027 130	1.250	TC 027
32	32	20	73	28	60	OTT 340 032 060	0.900	TC 032
	32	20	115	70	100	OTT 340 032 100	1.160	TC 032
	32	20	145	100	130	OTT 340 032 130	1.360	TC 032
42	42	24	89	33	75	OTT 340 042 075	0.970	TC 042
	42	24	175	119	160	OTT 340 042 160	1.910	TC 042
	42	24	215	159	200	OTT 340 042 200	2.390	TC 042
54	54	28	105	39	90	OTT 340 054 090	1.100	TC 054
	54	28	175	109	160	OTT 340 054 160	2.370	TC 054
	54	28	215	149	200	OTT 340 054 200	3.140	TC 054
68	68	36	176	90	160	OTT 340 068 160	2.570	TC 068
	68	36	216	130	200	OTT 340 068 200	3.730	TC 068
85	85	50	211	111	200	OTT 340 085 200	4.110	TC 068
100 200	100	60	211	111	200	OTT 340 100 200	5.010	TC 100

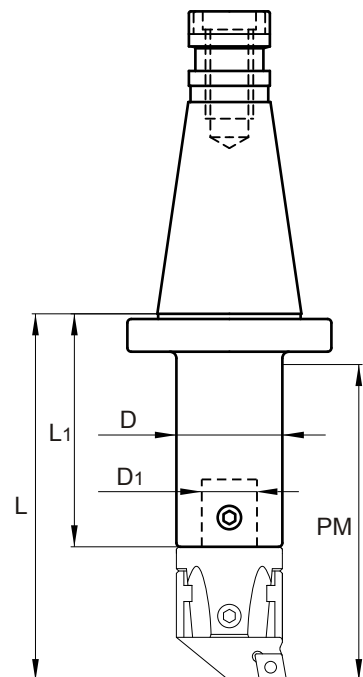

ARBORS FOR BORING HEADS

DIN 2080

OTT

ISO 50

SIZE	Dimension					Product Number	Kg.	Coupling Screw
	øD	øD1	L	L1	PM			
22	22	12	99	65	80	OTT 350 022 080	2.980	TC 022
	22	12	119	85	100	OTT 350 022 100	3.010	TC 022
27	27	15	71	29	55	OTT 350 027 055	2.930	TC 027
	27	15	119	77	100	OTT 350 027 100	3.090	TC 027
	27	15	149	107	130	OTT 350 027 130	3.200	TC 027
32	32	20	77	32	60	OTT 350 032 060	2.840	TC 032
	32	20	149	104	130	OTT 350 032 130	3.320	TC 032
	32	20	179	134	160	OTT 350 032 160	3.510	TC 032
42	42	24	93	37	75	OTT 350 042 075	2.920	TC 042
	42	24	179	123	160	OTT 350 042 160	3.870	TC 042
	42	24	219	163	200	OTT 350 042 200	4.380	TC 042
54	54	28	109	43	90	OTT 350 054 090	3.100	TC 054
	54	28	179	113	160	OTT 350 054 160	4.380	TC 054
	54	28	219	153	200	OTT 350 054 200	5.100	TC 054
68	68	36	132	46	115	OTT 350 068 115	3.290	TC 068
	68	36	220	134	200	OTT 350 068 200	5.820	TC 068
	68	36	280	194	260	OTT 350 068 260	7.590	TC 068
85	85	50	221	121	200	OTT 350 085 200	6.500	TC 068
	85	50	281	181	260	OTT 350 085 260	9.560	TC 068
	85	50	341	241	320	OTT 350 085 320	11.840	TC 068
100 200	100	60	193	93	170	OTT 350 100 170	5.680	TC 100
	100	60	281	181	260	OTT 350 100 260	11.250	TC 100
	100	60	341	241	320	OTT 350 100 320	15.100	TC 100
300 400 500	100	60	160	70	125	* OTT 550 160	5.910	TF 100

* SEE PAGES 46 AND 47: ASSEMBLY SYSTEM FOR LARGE BORING HEADS

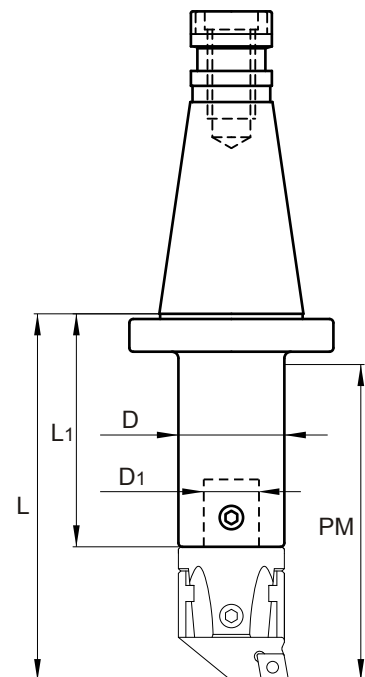

ARBORS FOR BORING HEADS

DIN 69893



HSK 50

SIZE	Dimension					Product Number	Kg.	Coupling Screw
	øD	øD1	L	L1	PM			
22	22	12	81	47	55	HSK 050A 022 055	0.490	TC 022
27	27	15	91	49	65	HSK 050A 027 065	0.570	TC 027
32	32	20	101	56	75	HSK 050A 032 075	0.660	TC 032
42	42	24	116	60	90	HSK 050A 042 090	0.730	TC 042



HSK 63

SIZE	Dimension					Product Number	Kg.	Coupling Screw
	øD	øD1	L	L1	PM			
22	22	12	81	47	55	HSK 063A 022 055	0.750	TC 022
27	27	15	91	49	65	HSK 063A 027 065	0.780	TC 027
32	32	20	101	56	75	HSK 063A 032 075	0.840	TC 032
42	42	24	116	60	90	HSK 063A 042 090	0.980	TC 042
54	54	28	136	70	110	HSK 063A 054 110	1.300	TC 054
68	68	36	171	85	145	HSK 063A 068 145	1.850	TC 068

HSK 100

SIZE	Dimension					Product Number	Kg.	Coupling Screw
	øD	øD1	L	L1	PM			
22	22	12	89	55	55	HSK 100A 022 055	2.280	TC 022
27	27	15	99	57	65	HSK 100A 027 065	2.350	TC 027
32	32	20	104	59	75	HSK 100A 032 075	2.330	TC 032
42	42	24	119	63	90	HSK 100A 042 090	2.470	TC 042
54	54	28	139	73	110	HSK 100A 054 110	2.800	TC 054
68	68	36	174	88	145	HSK 100A 068 145	3.510	TC 068
85	85	50	194	94	165	HSK 100A 085 165	4.150	TC 068
100	100	60	214	114	185	HSK 100A 100 185	5.670	TC 100
300	100	60	170	80	140	* HSK 550 160	5.240	TF 100

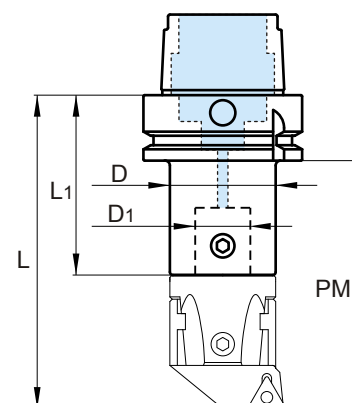

* SEE PAGES 46 AND 47: ASSEMBLY SYSTEM FOR LARGE BORING HEADS

ARBORS FOR BORING HEADS

DIN 228

MORSE 2,3,4

MORSE 2

SIZE	Dimension					Product Number	Kg.	Coupling Screw
	øD	øD1	L	L1	PM			
22	22	12	105	71	80	302 022 080	0.370	TC 022
27	27	15	73	31	55	302 027 055	0.200	TC 027
	27	15	128	83	100	302 027 100	0.480	TC 027

MORSE 3

SIZE	Dimension					Product Number	Kg.	Coupling Screw
	øD	øD1	L	L1	PM			
22	22	12	110	76	80	303 022 080	0.630	TC 022
27	27	15	78	36	55	303 027 055	0.410	TC 027
	27	15	130	88	100	303 027 100	0.680	TC 027
32	32	20	84	39	60	303 032 060	0.420	TC 032
	32	20	160	115	130	303 032 130	1.020	TC 032
42	42	24	114	58	90	303 042 090	0.700	TC 042
	42	24	160	104	130	303 042 130	1.250	TC 042

MORSE 4

SIZE	Dimension					Product Number	Kg.	Coupling Screw
	øD	øD1	L	L1	PM			
22	22	12	136	102	100	304 022 100	1.080	TC 022
	22	12	166	132	130	304 022 130	1.170	TC 022
27	27	15	82	40	55	304 027 055	0.800	TC 027
	27	15	137	95	100	304 027 100	1.080	TC 027
	27	15	167	125	130	304 027 130	1.240	TC 027
32	32	20	88	43	60	304 032 060	0.810	TC 032
	32	20	166	121	130	304 032 130	1.380	TC 032
	32	20	196	151	160	304 032 160	1.570	TC 032
42	42	24	104	48	75	304 042 075	0.870	TC 042
	42	24	166	110	130	304 042 130	1.570	TC 042
	42	24	196	140	160	304 042 160	1.970	TC 042
54	54	28	120	54	90	304 054 090	1.030	TC 054
	54	28	196	130	160	304 054 160	2.450	TC 054
	54	28	236	170	200	304 054 200	3.180	TC 054
68	68	36	235	149	200	304 068 200	3.870	TC 068
	68	36	295	209	260	304 068 260	5.890	TC 068

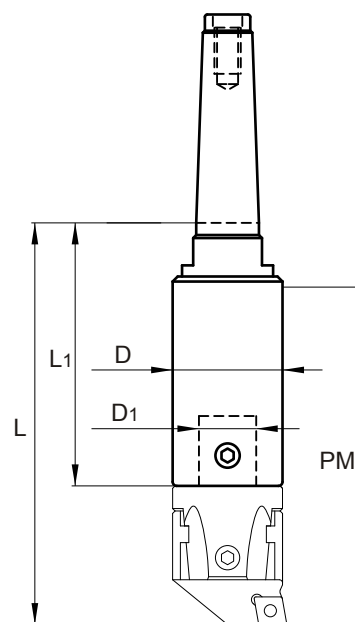

ARBORS FOR BORING HEADS

DIN 1806

MORSE 5

MORSE 5

SIZE	Dimension					Product Number	Kg.	Coupling Screw
	øD	øD1	L	L1	PM			
22	22	12	112	78	100	305 022 100	1.680	TC 022
	22	12	142	108	130	305 022 130	1.760	TC 022
27	27	15	65	23	55	305 027 055	1.580	TC 027
	27	15	113	71	100	305 027 100	1.720	TC 027
	27	15	143	101	130	305 027 130	1.860	TC 027
32	32	20	70	25	60	305 032 060	1.560	TC 032
	32	20	143	98	130	305 032 130	1.970	TC 032
	32	20	173	128	160	305 032 160	2.160	TC 032
42	42	24	83	27	75	305 042 075	1.520	TC 042
	42	24	188	86	130	305 042 130	2.220	TC 042
	42	24	218	116	160	305 042 160	2.520	TC 042
54	54	28	172	106	160	305 054 160	3.040	TC 054
	54	28	212	146	200	305 054 200	3.770	TC 054
68	68	36	146	60	140	305 068 140	2.560	TC 068
	68	36	212	126	200	305 068 200	4.470	TC 068
	68	36	272	186	260	305 068 260	6.560	TC 068
85	85	50	216	116	200	305 085 200	5.400	TC 068
	85	50	276	176	260	305 085 260	8.450	TC 068
	85	50	336	236	320	305 085 320	10.810	TC 068
100 200	100	60	276	176	260	305 100 260	8.440	TC 100
	100	60	336	236	320	305 100 320	11.430	TC 100
300 400 500	100	60	146	56	140	* 505 160	4.700	TF 100

* SEE PAGES 46 AND 47: ASSEMBLY SYSTEM FOR LARGE BORING HEADS

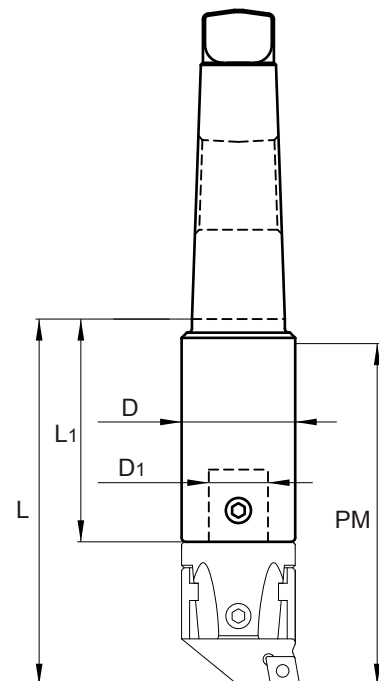

NOTE: MORSE 6 ARBORS CAN BE MANUFACTURED AS "SPECIAL" UPON REQUEST

ARBORS FOR BORING HEADS

DIN 1835

WELDON

WELDON Ø20, Ø25, Ø32, Ø40

SIZE	Dimension					Product Number	Kg.	Coupling Screw
	øD	øD1	øD2	L	PM			
22	20	22	12	16	50	B 020 022 050	0.170	TC 022
	20	22	12	70	100	B 020 022 100	0.350	TC 022
27	25	27	15	14	55	B 025 027 055	0.260	TC 027
	25	27	15	58	100	B 025 027 100	0.470	TC 027
32	32	32	20	18	60	B 032 032 060	0.440	TC 032
	32	32	20	58	100	B 032 032 100	0.700	TC 032
	32	32	20	118	160	B 032 032 160	1.150	TC 032
42	32	42	24	40	90	B 032 042 090	0.730	TC 042
42	40	42	24	36	90	B 040 042 090	1.000	TC 042
	40	42	24	106	160	B 040 042 160	1.820	TC 042

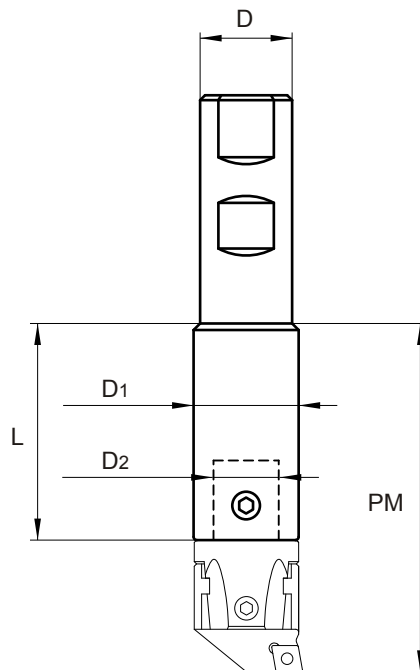

ARBORS FOR BORING HEADS

BRIDGEPORT

R8 HOLDERS

SIZE	Dimension					Product Number	Kg.	Coupling Screw
	øD	øD1	L	L1	PM			
22	22	12	54	20	50	R8 022 050	0.490	TC 022
27	27	15	64	22	60	R8 027 060	0.510	TC 027
32	32	20	79	34	75	R8 032 075	0.590	TC 032
42	42	24	95	39	90	R8 042 090	0.720	TC 042
54	54	28	114	48	110	R8 054 110	1.070	TC 054

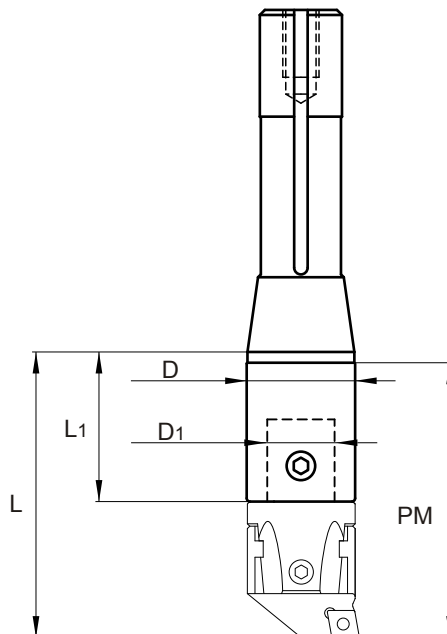

ACCESSORIES

EXTENSION PIECES

SIZE	Dimension				Product Number	Kg.	Coupling Screw
	øD	øD1	øD2	L			
22	22	12	12	20	P 022 020	0.060	TC 022
	22	12	12	30	P 022 030	0.090	TC 022
27	27	15	15	30	P 027 030	0.140	TC 027
	27	15	15	45	P 027 045	0.200	TC 027
32	32	20	20	35	P 032 035	0.210	TC 032
	32	20	20	52	P 032 052	0.300	TC 032
42	42	24	24	40	P 042 040	0.410	TC 042
	42	24	24	60	P 042 060	0.620	TC 042
54	54	28	28	50	P 054 050	0.880	TC 054
	54	28	28	75	P 054 075	1.320	TC 054
68	68	36	36	60	P 068 060	1.660	TC 068
	68	36	36	90	P 068 090	2.480	TC 068
85	85	50	50	70	P 085 070	2.940	TC 068
	85	50	50	105	P 085 105	4.420	TC 068
100 200	100	60	60	80	P 100 080	4.580	TC 100
	100	60	60	120	P 100 120	7.060	TC 100

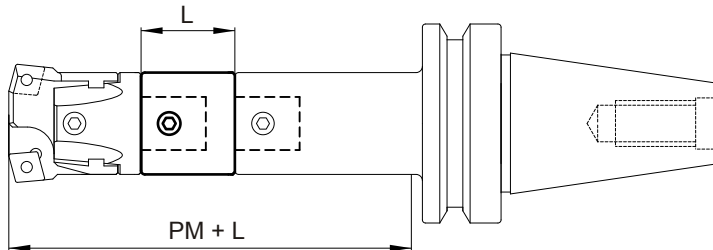
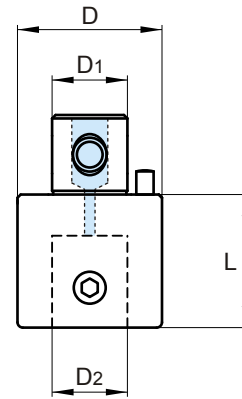

COOLANT-FEEDING EXTENSIONS (PROVIDES FLOOD COOLANT)

SIZE	Dimension				Product Number	Kg.	Coupling Screw
	øD	øD1	øD2	L			
22	22	12	12	30	P 022 030 R	0.090	TC 022
27	27	15	15	30	P 027 030 R	0.140	TC 027
32	32	20	20	35	P 032 035 R	0.210	TC 032
42	42	24	24	40	P 042 040 R	0.410	TC 042
54	54	28	28	50	P 054 050 R	0.880	TC 054
68	68	36	36	60	P 068 060 R	1.660	TC 068
85	85	50	50	70	P 085 070 R	2.940	TC 068
100 200	100	60	60	80	P 100 080 R	4.580	TC 100

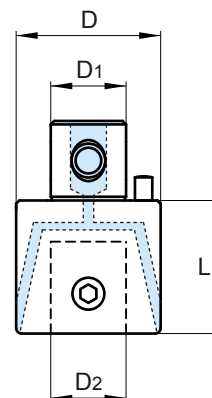

NOTE: Arbors to match with coolant-feeding extensions must be ordered by adding "R" at the end of the product number.

Standard Execution:

BT 340 022 050

Coolant Execution:

BT 340 022 050 R

ACCESSORIES

REDUCERS

SIZE	Dimension						Product Number	Kg.	Coupling Screw
	øD	øD1	øD2	øD3	L	L1			
22	27	15	22	12	26	10	R 027 022 036	0.130	TC 022
	32	20	22	12	30	10	R 032 022 040	0.180	TC 022
	42	24	22	12	48	10	R 042 022 058	0.320	TC 022
	54	28	22	12	76	10	R 054 022 086	0.510	TC 022
	68	36	22	12	90	12	R 068 022 102	0.900	TC 022
27	32	20	27	15	24	10	R 032 027 034	0.190	TC 027
	42	24	27	15	40	10	R 042 027 050	0.340	TC 027
	54	28	27	15	70	10	R 054 027 080	0.640	TC 027
	68	36	27	15	83	12	R 068 027 095	0.980	TC 027
32	42	24	32	20	36	10	R 042 032 046	0.360	TC 032
	54	28	32	20	66	10	R 054 032 076	0.700	TC 032
	68	36	32	20	78	12	R 068 032 090	1.090	TC 032
42	54	28	42	24	60	10	R 054 042 070	0.880	TC 042
	68	36	42	24	70	12	R 068 042 082	1.310	TC 042
	85	50	42	24	83	12	R 085 042 095	2.080	TC 042
54	68	36	54	28	60	12	R 068 054 072	1.520	TC 054
	85	50	54	28	78	12	R 085 054 090	2.460	TC 054
68	85	50	68	36	88	12	R 085 068 100	3.320	TC 068
85	100	60	85	50	88	12	R 100 085 100	5.040	TC 068

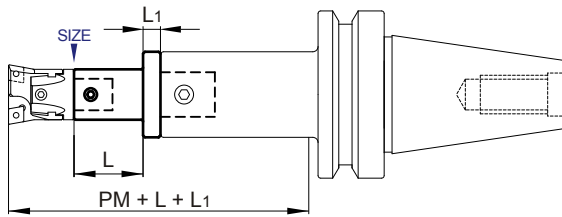
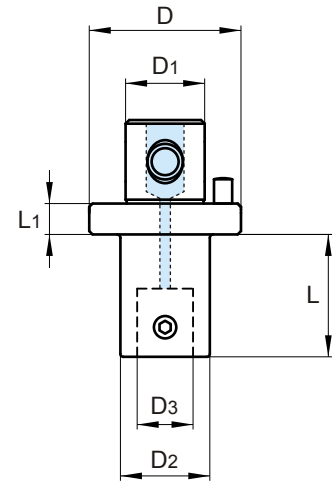

45° CHAMFERING HEADS

SIZE	Dimension			Product Number	Insert	Torx Screw	Kg.	Key	
	øD	øD1	L					Torx Key	Locking Key
22	22	43	24	CH 022	DC□□ 11T3□□	TT 409	0.140	TK 15	HK 040
27	27	48	24	CH 027	DC□□ 11T3□□	TT 409	0.160	TK 15	HK 040
32	32	62	30	CH 032	DC□□ 11T3□□	TT 409	0.300	TK 15	HK 050
42	42	72	30	CH 042	DC□□ 11T3□□	TT 409	0.400	TK 15	HK 050
54	54	94	40	CH 054	DC□□ 1504□□	TT 402	0.910	TK 20	HK 060
68	68	110	40	CH 068	DC□□ 1504□□	TT 402	1.230	TK 20	HK 080
85	85	145	55	CH 085	DC□□ 1504□□	TT 402	2.700	TK 20	HK 100
100	100	170	60	CH 100	DC□□ 1504□□	TT 402	4.140	TK 20	HK 140
200	100	200	60	CH 200	DC□□ 1504□□	TT 402	5.800	TK 20	HK 140

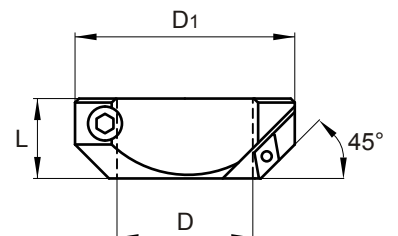

ACCESSORIES

ADAPTORS

MILLING CUTTER HOLDER

SIZE	Dimension				Product Number	Kg.
	øD	øD1	øD2	L		
42	42	24	16	14	ADM 042 016	0.230
	42	24	22	12	ADM 042 022	0.280
54	54	28	16	30	ADM 054 016	0.600
	54	28	22	28	ADM 054 022	0.660
	54	28	27	18	ADM 054 027	0.720
68	68	36	16	25	ADM 068 016	0.930
	68	36	22	23	ADM 068 022	0.870
	68	36	27	21	ADM 068 027	0.900
	68	36	32	26	ADM 068 032	0.950
85	85	50	32	25	ADM 085 032	1.850
	85	50	40	30	ADM 085 040	2.250

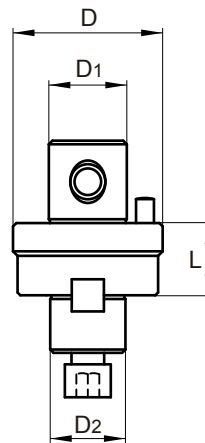

WELDON

SIZE	Dimension				Product Number	Kg.
	øD	øD1	øD2	L		
42	42	24	6	35	ADM 042 W06	0.250
	42	24	8	35	ADM 042 W08	0.270
	42	24	10	38	ADM 042 W10	0.360
	42	24	12	55	ADM 042 W12	0.620
	48	24	16	60	ADM 042 W16	0.830
54	52	24	20	65	ADM 042 W20	0.990
	54	28	16	60	ADM 054 W16	0.950
	54	28	20	65	ADM 054 W20	1.160
	54	28	25	70	ADM 054 W25	1.650

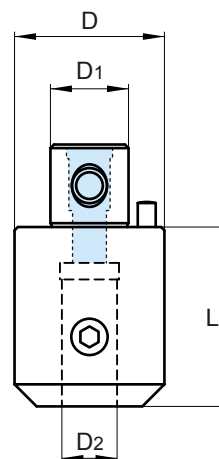

ACCESSORIES

ADAPTORS

MORSE

SIZE	Dimension					Product Number	Kg.
	øD	øD1	øD2	øD3	L		
42	42	24	17.780	30	90	ADM 042 CM2	0.650
	42	24	23.825	36	110	ADM 042 CM3	0.810
54	54	28	17.780	30	90	ADM 054 CM2	0.730
	54	28	23.825	36	110	ADM 054 CM3	0.920

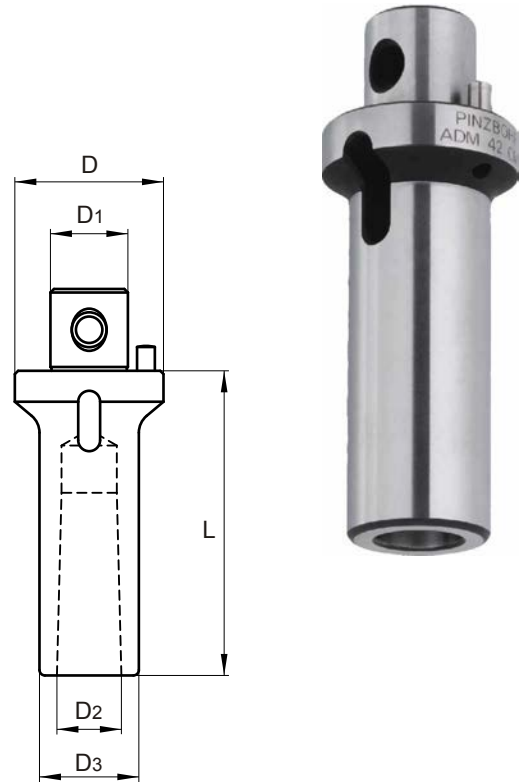

DIN 238 (FOR DRILL CHUCKS)

SIZE	Dimension				Product Number	Kg.
	øD	øD1	øD2	L		
42	42	24	12.065	8	ADM 042 B12	0.220
54	54	28	12.065	10	ADM 054 B12	0.440
	54	28	15.733	10	ADM 054 B16	0.400
68	68	36	15.733	12	ADM 068 B16	0.770

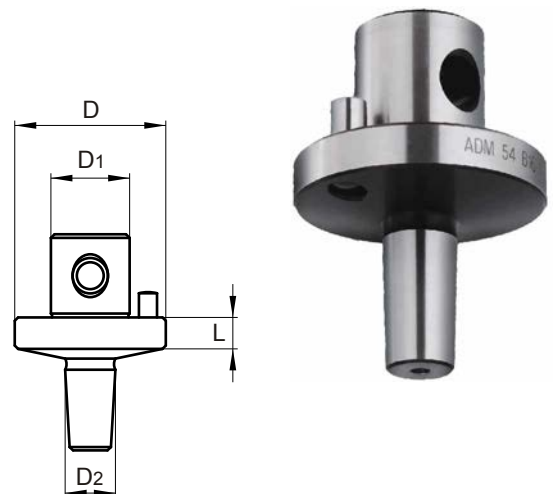

SPARE PARTS

ROUGH BORING HEADS

INTEGRAL POCKET TYPE

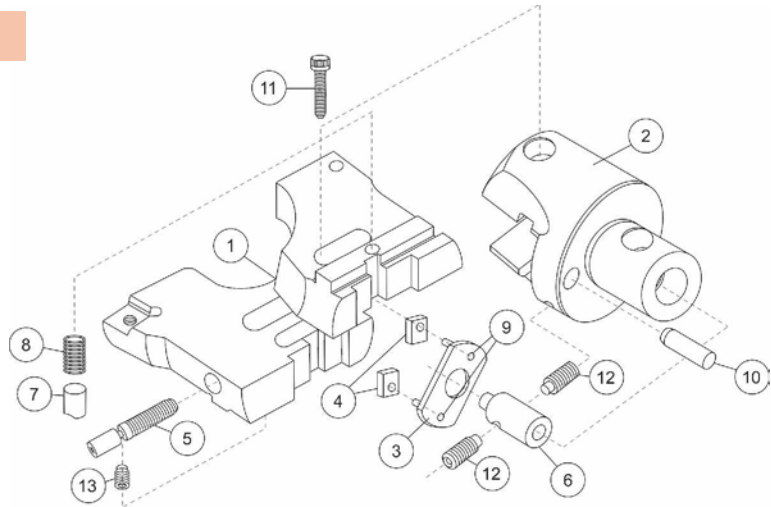

SIZE	Boring Head	1 (set of slides)	2	3	4	5	6	7	8	9	10	11	12	13
22	D 02275 □□□	D 02275 01 □□□	D 022 03	D 022 04	-	D 022 06			D 022 09		D 022 20	D 022 21	D 022 22	D 022 23
	D 02290 □□□	D 02290 01 □□□					D 022 07	D 022 08		D 022 19				
27	D 02775 □□□	D 02775 01 □□□	D 027 03	D 027 04	-	D 027 06			D 027 09		D 027 20	D 027 21	D 027 22	D 027 23
	D 02790 □□□	D 02790 01 □□□												
32	D 03275 □□□	D 03275 01 □□□	D 032 03	D 032 04	-	D 032 06	D 032 07	D 032 08	D 032 09	D 032 19	D 032 20	D 032 21	D 032 22	D 032 23
	D 03290 □□□	D 03290 01 □□□												
42	D 04275 □□□	D 04275 01 □□□	D 042 03	D 042 04		D 042 06	D 042 07	D 042 08			D 042 20	D 042 21	D 042 22	
	D 04290 □□□	D 04290 01 □□□			D 042 05				D 042 09	D 022 20				D 042 23
54	D 05475 □□□	D 05475 01 □□□	D 054 03	D 054 04		D 054 06	D 054 07	D 054 08			D 054 20	D 054 21	D 054 22	
	D 05490 □□□	D 05490 01 □□□												

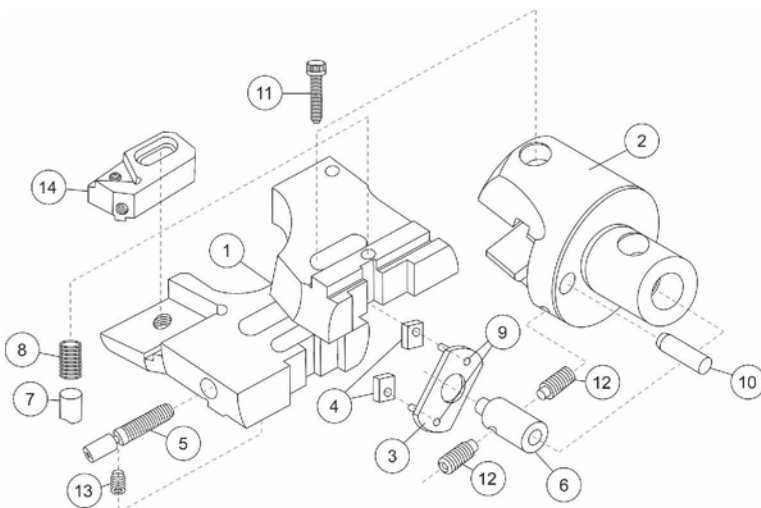

CARTRIDGE TYPE

SIZE	Boring Head	14
68	D 068□□ □□□	2CT □□ □□□
85	D 085□□ □□□	3CT □□ □□□
100	D 100□□ □□□	3CT □□ □□□
200	D 200□□ □□□	3CT □□ □□□

SIZE	Boring Head	1 (set of slides)	2	3	4	5	6	7	8	9	10	11	12	13
68	D 068□□ □□□	D 06800 01 2CT	D 068 03	D 068 04	D 068 05	D 068 06	D 068 07	D 068 08	D 068 09	D 068 19	D 068 20	D 068 21	D 068 22	D 068 23
85	D 085□□ □□□	D 08500 01 3CT	D 085 03	D 085 04		D 085 06	D 085 07	D 085 08			D 085 20	D 085 21		
100	D 100□□ □□□	D 10000 01 3CT	D 100 03		D 085 05	D 100 06			D 085 09	D 085 19			D 085 22	D 085 23
200	D 200□□ □□□	D 20000 01 3CT	D 200 03	D 100 04		D 200 06	D 100 07	D 100 08			D 100 20	D 100 21		

SPARE PARTS

FINISH BORING HEADS

INTEGRAL POCKET TYPE

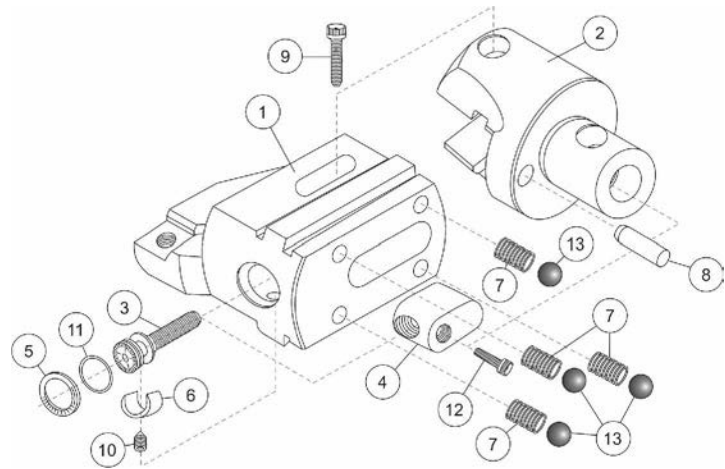

SIZE	Boring Head	1	2	3	4	5	6	7	8	9	10	11	12	13
22	A 02275 □□□	A 02275 02 □□□	A 022 03	A 022 13				A 022 17	D 022 20	D 022 21	D 022 23		A 022 26	A 022 30
	A 02290 □□□	A 02290 02 □□□			A 022 14	A 022 15	A 022 16							
27	A 02775 □□□	A 02775 02 □□□	A 027 03	A 027 13					D 027 20	D 027 21	D 027 23	A 022 25	A 027 26	
	A 02790 □□□	A 02790 02 □□□						A 027 17						A 027 30
32	A 03275 □□□	A 03275 02 □□□	A 032 03	A 032 13	A 032 14	A 032 15	A 032 16		D 032 20	D 032 21	D 032 23		A 032 26	
	A 03290 □□□	A 03290 02 □□□												
42	A 04275 □□□	A 04275 02 □□□	A 042 03	A 042 13	A 042 14			A 042 17	D 042 20	D 042 21				A 042 30
	A 04290 □□□	A 04290 02 □□□				A 042 15	A 042 16				D 042 23	A 042 25	A 042 26	
54	A 05475 □□□	A 05475 02 □□□	A 054 03	A 054 13	A 054 14				D 042 09	D 054 20	D 054 21			A 054 30
	A 05490 □□□	A 05490 02 □□□												

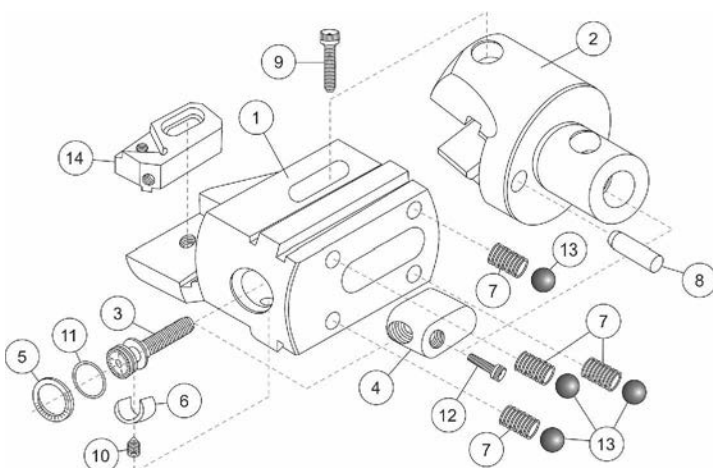

CARTRIDGE TYPE

SIZE	Boring Head	14
68	A 068□□ □□□	2CT □□ □□□
85	A 085□□ □□□	3CT □□ □□□
100	A 100□□ □□□	3CT □□ □□□
200	A 200□□ □□□	3CT □□ □□□

SIZE	Boring Head	1	2	3	4	5	6	7	8	9	10	11	12	13
68	A 068□□ □□□	A 06800 02 2CT	A 068 03	A 068 13	A 068 14	A 068 15	A 068 16	A 068 17	D 068 20	D 068 21	D 068 23	A 068 25	A 068 26	A 068 30
85	A 085□□ □□□	A 08500 02 3CT	A 085 03	A 085 13					D 085 20	D 085 21				
100	A 100□□ □□□	A 10000 02 3CT	A 100 03		A 085 14	A 085 15	A 085 16	D 085 09				D 085 23	A 085 25	A 085 26
200	A 200□□ □□□	A 20000 02 3CT	A 200 03	A 200 13					D 100 20	D 100 21				

SPARE PARTS

LARGE BORING HEADS

ROUGHING

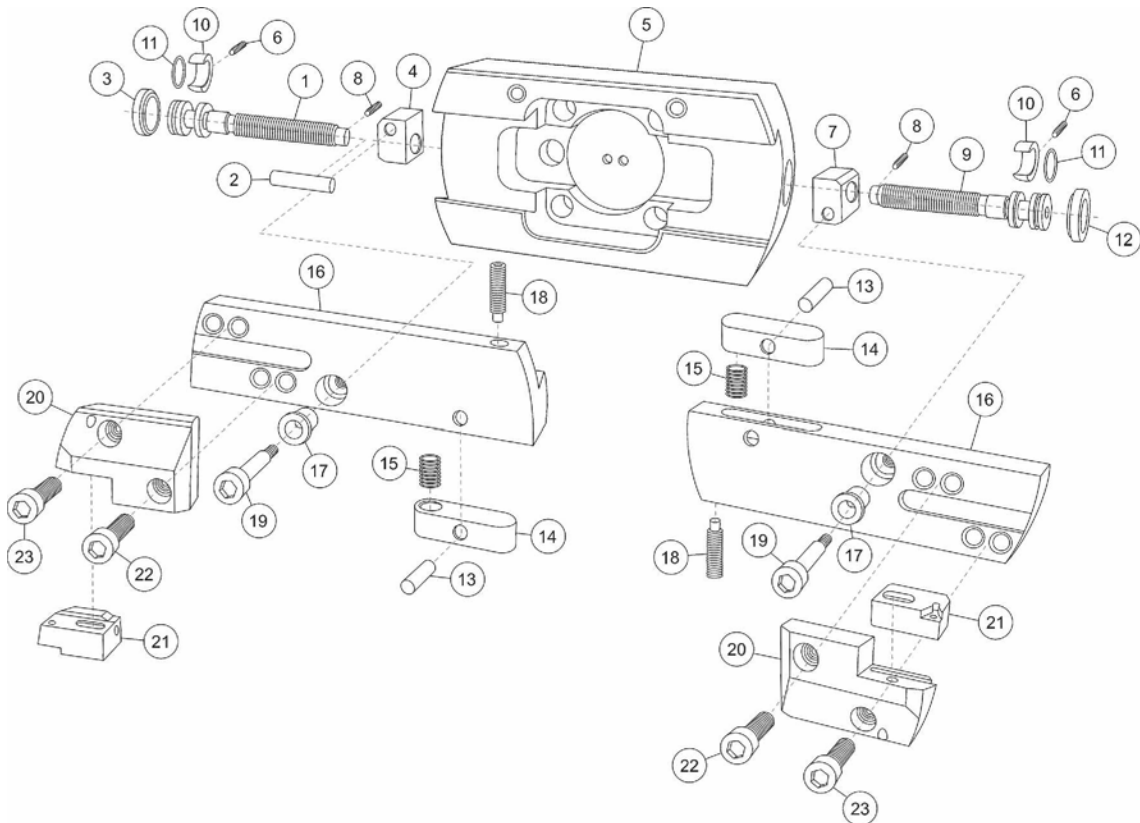

SIZE	Boring Head	1	2	3	4	5	6	7	8	9	10	11	12	13	14	15	16	17	18	19	20	21	22	23
300	D 300□□ □□	D 300 51	D 300 66	A 068 15	D 300 55	D 300 03	D 068 23	D 300 54	D 300 65	D 300 50	A 068 16	A 068 25	D 300 15	D 300 60	D 300 56	D 300 59	D 300 01	D 300 62	D 300 58	D 300 57	D 300 49	3CT □□ □□	D 300 61	D 300 67
400	D 400□□ □□	D 400 51	D 300 66	A 068 15	D 300 55	D 400 03	D 068 23	D 300 54	D 300 65	D 400 50	A 068 16	A 068 25	D 300 15	D 300 60	D 300 56	D 300 59	D 400 01	D 300 62	D 300 58	D 300 57	D 300 49	3CT □□ □□	D 300 61	D 300 67
500	D 500□□ □□	D 500 51	D 300 66	A 068 15	D 300 55	D 500 03	D 068 23	D 300 54	D 300 65	D 500 50	A 068 16	A 068 25	D 300 15	D 300 60	D 300 56	D 300 59	D 500 01	D 300 62	D 300 58	D 300 57	D 300 49	3CT □□ □□	D 300 61	D 300 67

SPARE PARTS

LARGE BORING HEADS

FINISHING

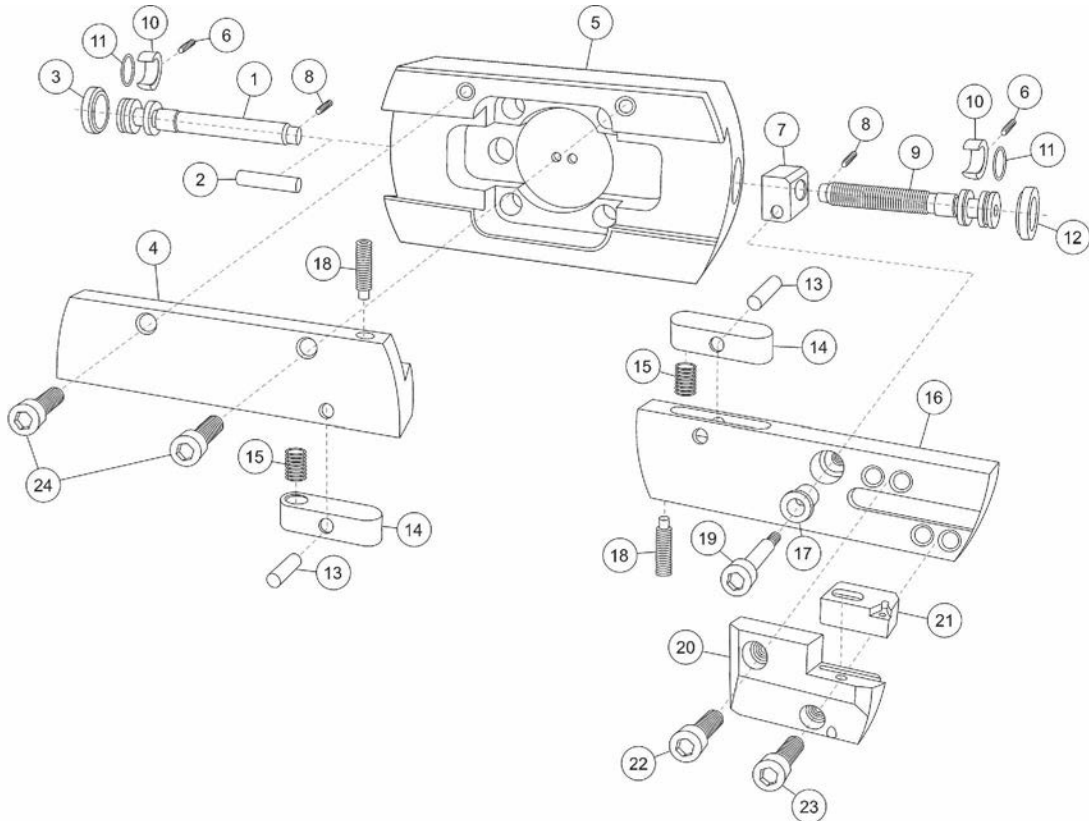

SIZE	Boring Head	1	2	3	4	5	6	7	8	9	10	11	12	13	14	15	16	17	18	19	20	21	22	23	24
300	A 300□□ □□□	A 300 52	D 300 66	A 068 15	A 300 02	D 300 03	D 068 23	D 300 54	D 300 65	D 300 50	A 068 16	A 068 25	D 300 15	D 300 60	D 300 56	D 300 59	D 300 01	D 300 62	D 300 58	D 300 57	D 300 49	3CT □□ □□□	D 300 61	D 300 67	A 300 63
400	A 400□□ □□□	A 400 52	D 300 66	A 068 15	A 400 02	D 400 03	D 068 23	D 300 54	D 300 65	D 400 50	A 068 16	A 068 25	D 300 15	D 300 60	D 300 56	D 300 59	D 400 01	D 300 62	D 300 58	D 300 57	D 300 49	3CT □□ □□□	D 300 61	D 300 67	A 300 63
500	A 500□□ □□□	A 500 52	D 300 66	A 068 15	A 500 02	D 500 03	D 068 23	D 300 54	D 300 65	D 500 50	A 068 16	A 068 25	D 300 15	D 300 60	D 300 56	D 300 59	D 500 01	D 300 62	D 300 58	D 300 57	D 300 49	3CT □□ □□□	D 300 61	D 300 67	A 300 63

ASSEMBLY SYSTEM FOR LARGE BORING HEADS

ARBORS FOR LARGE BORING HEADS

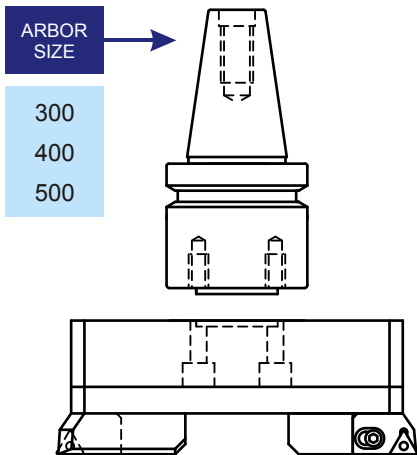

ARBOR
SIZE

- 300
- 400
- 500

Product Number	Coupling Screws
BT 550 160	TF 100
AS 550 160	
OTT 550 160	
HSK 550 160	
505 160	

**DIRECT
MOUNT**



ADAPTOR FOR SIZE 100 200 STANDARD PINZBOHR ARBORS

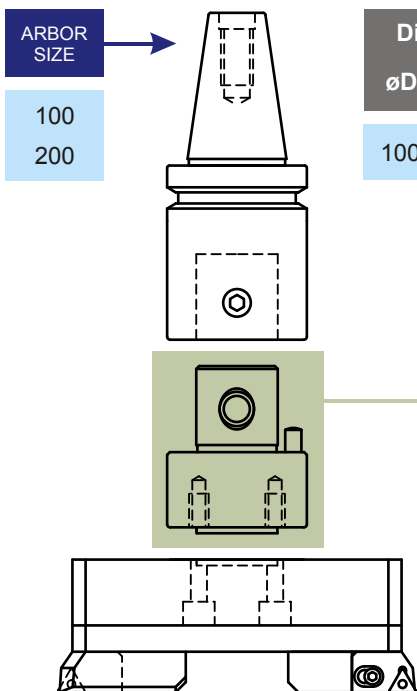

ARBOR
SIZE

- 100
- 200

Dimension			Product Number	Kg.	Coupling Screws
$\varnothing D$	$\varnothing D_1$	L			
100	60	50	ADT 100 050	4.360	TF 100

**ADAPTOR
MOUNT**

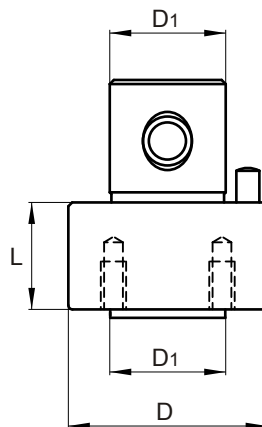

ASSEMBLY SYSTEM FOR LARGE BORING HEADS

INSTRUCTIONS OF USE AND ASSEMBLY ON ARBOR OR ADAPTOR FOR LARGE DIAMETER BORING HEADS

1. Loosen both slide locking screws *D 300 58*.
2. Remove nut clamp screw/s *D 300 57* (one in finish boring heads, two in rough boring heads).
3. On finish boring heads only, remove fixed slide screws *A 300 63*.
4. Move the slides outwards until the four counterbored bolt holes of the *TF 100* screws located in the body are completely exposed.
5. Place the arbor or adaptor on the back side of the boring head and fix it with the four *TF 100* screws.
6. Move the slides inwards to its original position.
7. Insert nut clamp screw/s *D 300 57* (one in finish boring heads, two in rough boring heads) with care not to tighten in excess due to the fact that the nut is made of bronze and its M6 thread could be damaged.
8. Adjust the boring head to the required diameter and tighten both slide locking screws *D 300 58* considering that, in order to achieve the full boring range, cartridge base *D 300 49* has two possible positions spaced 15 mm among them.

ROUGHING

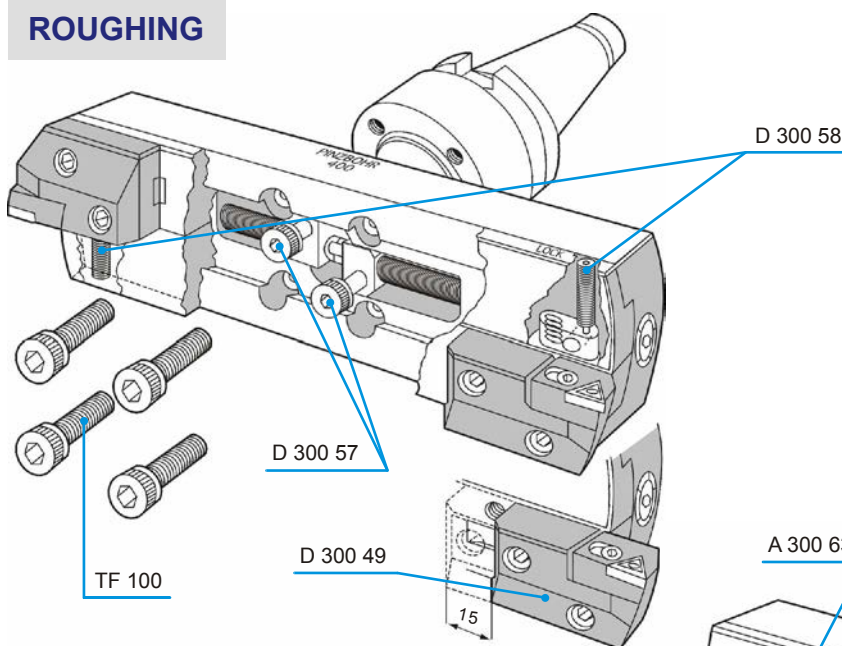

FINISHING

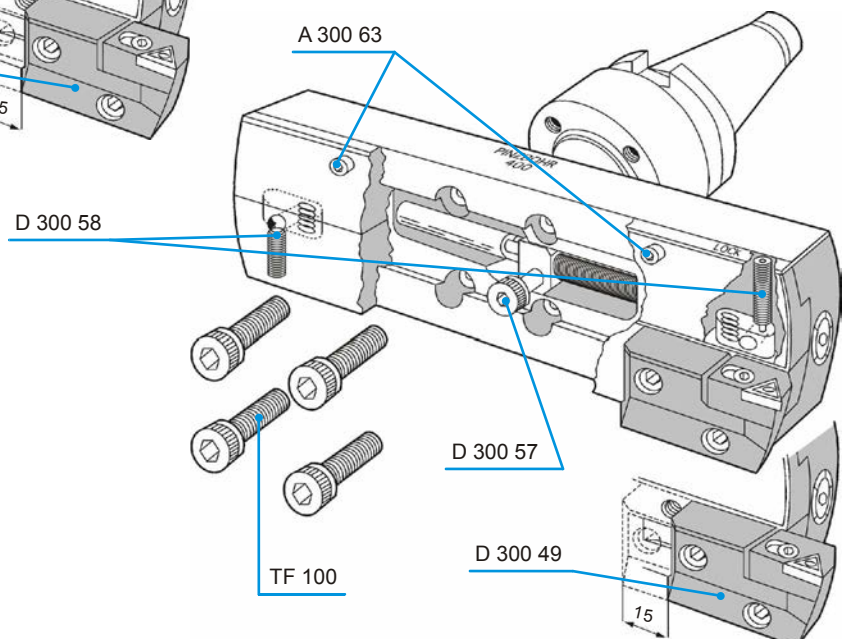

BORING KITS

Bohrstar 54



BORING KITS from $\varnothing 6$ mm up to 210 mm



FOR PRECISE INFORMATION SEE OUR **BOHRSTAR 54** CATALOG

BORING KITS

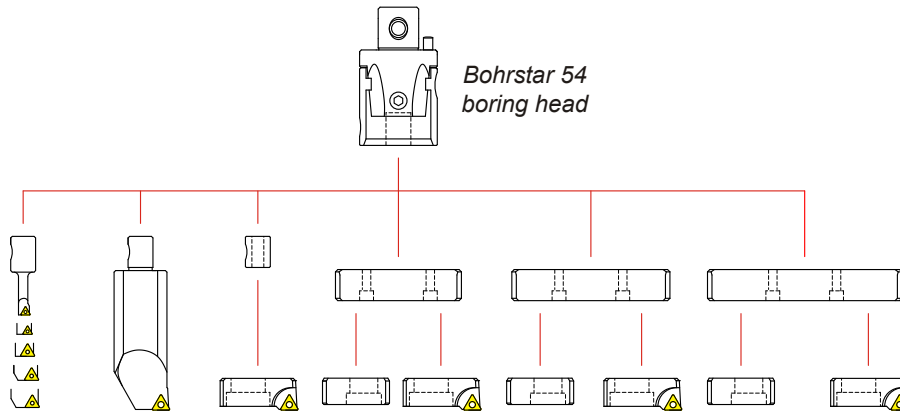

From	Ø 6 / 8	Ø 38	Ø 56	Ø 85	Ø 125	Ø 165
To	Ø 43	Ø 59	Ø 100	Ø 130	Ø 170	Ø 210

Range		Components	Ordering Number
Ø 8 ~			BS 54 KIT T 8-210
Ø 210			BS 54 KIT R 8-210
Ø 8 ~			BS 54 KIT T 8-170
Ø 170			BS 54 KIT R 8-170
Ø 8 ~			BS 54 KIT T 8-100
Ø 100			BS 54 KIT R 8-100
Ø 8 ~			BS 54 KIT T 8-043
Ø 43			BS 54 KIT R 8-043
Ø 6 ~			BS 54 KIT R 6-210
Ø 210			
Ø 6 ~			BS 54 KIT R 6-170
Ø 170			
Ø 6 ~			BS 54 KIT R 6-100
Ø 100			
Ø 6 ~			BS 54 KIT R 6-043
Ø 43			

Features

- Several hole solutions with only one boring head.
- Rhombic or triangular kit insert choice.
- Bohrstar 54 boring head readout precision of 0.002 mm Ø.
- Bohrstar 54 boring head matches with all arbors and accessories size 54 shown on this main catalog.

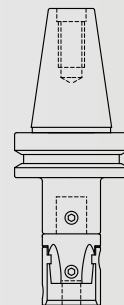

FOR PRECISE INFORMATION SEE OUR **BOHRSTAR 54** CATALOG

TOOL PRESETTERS

**DIGITAL DISPLAY
INTEGRATED OPTICAL SYSTEM**

ADI

	ADI 1	ADI 2
Taper Style	ISO 40	ISO 50
Maximum Diameter	230	300
Maximum Height	300	400



BWT

**DIGITAL DISPLAY
PRECISION DIAL INDICATOR**

	BWT A	BWT B
Taper Style	ISO 40	ISO 50
Maximum Diameter	230	300
Maximum Height	300	400

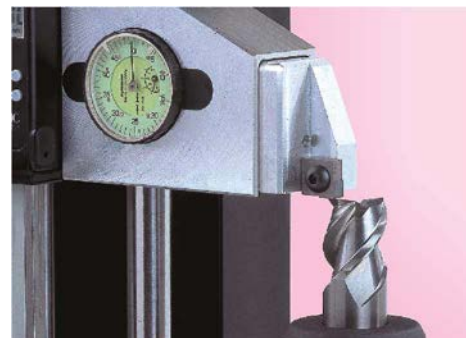

FOR ADDITIONAL INFORMATION THERE IS A SPECIFIC CATALOG

TOOL PRESETTERS



TWO DIGITAL DISPLAYS

TPR	302	402
Taper Style	ISO 40	ISO 50
Maximum Diameter	200	300
Maximum Height	300	400

FOR ADDITIONAL INFORMATION THERE IS A SPECIFIC CATALOG

TOOL LOCKING FIXTURE

TLF 40

Taper Style	ISO 40
Dimensions	120 x 150 x 120
Kg.	0,550









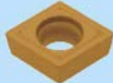

Mounted on a work table a strong gripping power on the taper enables assembling and disassembling cutting tools and pull studs.

- Horizontal and vertical taper position.
- Hard polyamide, fiber reinforced, prevents tool damages.
- 4 positioning magnets enable the right adhesion in horizontal position.



INSERTS

Shape	Pinzbohr code	ISO code
	300 306 309	TC□□ 16T3□□ TC□□ 06T1□□ TC□□ 0902□□
	310 311	TP□□ 0902□□ TP□□ 1103□□
	400 401 402 409	CC□□ 0602□□ CC□□ 0803□□ CC□□ 1204□□ CC□□ 09T3□□
	402 N	CN□□ 1204□□

Shape	Pinzbohr code	ISO code
	404 405	EP□□ 0401□□ L EP□□ 0502□□
	411 415	DC□□ 11T3□□ DC□□ 1504□□
	502 509	SC□□ 1204□□ SC□□ 09T3□□
	W06 W08	WC□□ 06T3□□ WC□□ 0804□□

INSERT SCREWS



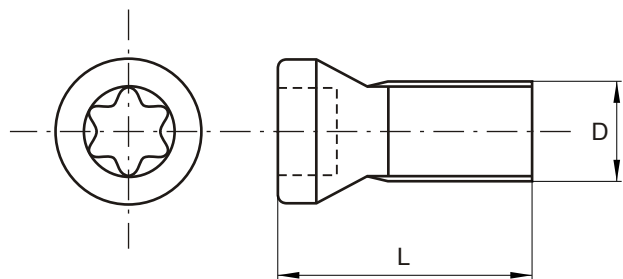







Torx Screw	Dimension D x L	Torx Key
TT 100	M2X3.3	TK 06
TT 102	M2X4	TK 06
TT 104	M2X4.9	TK 06
TT 106	M2.2X5.6	TK 07
TT 108	M2.2X6.4	TK 07
TT 110	M2.5X4.8	TK 08
TT 112	M3.5X8.5	TK 09
TT 114	M4X8.8	TK 15
TT 116	M5X9.5	TK 20
TT 300	M4X15	TK 15
TT 400	M2.5X6	TK 08
TT 401	M3X7.6	TK 10
TT 402	M5X13	TK 20
TT 402 N	M6.3X13.2	HK 025 
TT 409	M4X8.5	TK 15















 HEXAGONAL KEY

NOMENCLATURE FOR INSERTS

1 Shape

C 	D 	E 	K 	L 
R 	S 	T 	V 	W 

4 Chipbreaker and hole

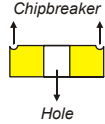
A 	F 	G 	H 	M 
N 	P 	Q 	R 	T 
U 	W 	X Others (particular design)		

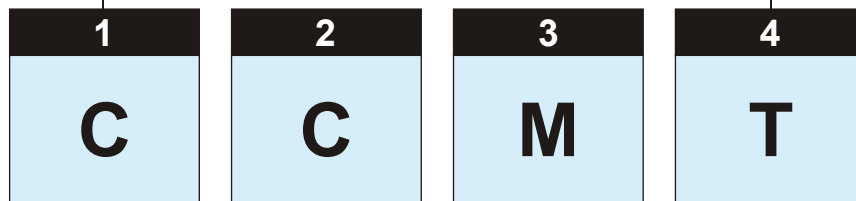

Example:

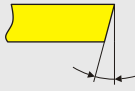

2 Relief angle

	
A	3°
B	5°
C	7°
D	15°
E	20°
F	25°
G	30°
N	0°
P	11°
O	Others

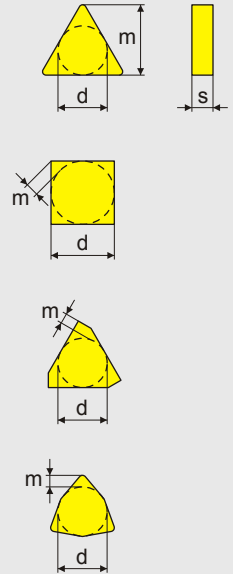
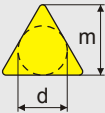
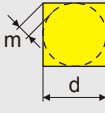
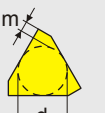
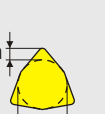
3 Tolerance (mm)

Symbol	Corner height m	Thickness s	Inscribed circle ϕd	
A	± 0.005	± 0.025	± 0.025	
F			± 0.013	
C	± 0.013	± 0.025	± 0.025	
H			± 0.013	
E	± 0.025	± 0.13	± 0.025	
G			± 0.025	
J	± 0.005	± 0.025	± 0.05 - ± 0.15	
K	± 0.013			
L	± 0.025	± 0.13	± 0.08 - ± 0.18	
M	± 0.025			
N	± 0.08 ~ ± 0.18	± 0.025	± 0.08 - ± 0.25	
U	± 0.13 ~ ± 0.38	± 0.13		

NOMENCLATURE FOR INSERTS

6 Thickness

Positive insert 

Negative insert 

Symbol	s (mm)
01	1.59
02	2.38
T2	2.78
03	3.18
T3	3.97
04	4.76
05	5.56
06	6.35
07	7.94
09	9.52

7 Corner radius



Symbol	r (mm)
01	0 ~ 0.1
02	0.2
04	0.4
08	0.8
12	1.2
16	1.6
20	2.0
24	2.4
28	2.8
32	3.2

9 Hand of insert

Optional

R 

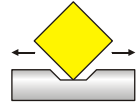
N 

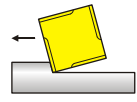
L 

10 Chipbreaker

Optional

Supplementary symbol specific to the manufacturer.
Identification of chipbreaker.

5
12

6
04







7
08

8
-

9
-

10
PS

5 Cutting edge length / Inscribed circle

Cutting edge length Symbol							Inscribed circle Ø (mm)
							
03	04		03	06			3.97
04	05		04	08	08		4.76
		05					5
05	06		05	09		03	5.56
		06					6
06	07		06	11	11	04	6.35
08	09		07	13		05	7.94
		08					8
09	11	09	09	16	16	06	9.525
	12	10					10
		12					12
12	15	12	12	22	22	08	12.7
16	19	15	15	27	27	10	15.875
		16					16
19	23	19	19	33	33	13	19.05
		20					20
22	27		22	38			22.225
		25					25
25	31	25	25	44	44	17	25.4
32	38	31	31	54	54	21	31.75
		32					32

8 Cutting edge

Optional

F 

E 

T 

S 

APPLICATION HINTS



SPEEDS AND FEEDS

Ultimate or optimum speeds and feeds will depend upon material, machine and setup conditions, as well as tool overhang.

BORING DEPTH - TOOL OVERHANG FOR ROUGHING AND FINISHING

Under conditions suited for carbide tooling depths of 5x \emptyset for rough boring and 3x \emptyset for finish boring are achievable. With the increasing overhang, the mechanical stability of the tool body decreases. Overlength tools will have a tendency for deflections as well as harmonic (high pitch) chatter. Harmonic chatter can cause movement of adjusting components inside the boring head leading to off-size or tapered holes.

In many cases the high pitch harmonic chatter can be dampened by increasing the feed and (or) lowering the cutting speed.

Please note that the cutting behavior will also change with the amount of slide block (insert holder) extension from the boring head requiring adjustments regarding speeds and feeds.

BORING DEPTH - TOOL OVERHANG FOR MICRO BORING HEADS

The maximum boring depth with steel boring bars should not exceed 5x bar diameter and 7x bar diameter with solid carbide bars. We recommend to shorten the bars to the shortest overhang necessary according to the required boring depth.

ROUGH BORING HEAD 75° vs. 90°

The 75° rough boring head should be used whenever a lot of stock is being removed and no square shoulder is required inside of blind or stepped hole. The 75° lead has a tendency to self-center to the pre-existing hole and therefore cut very stable. If this pre-existing hole, is off-center, shifted or off-angle then it is recommended to use the 90° boring head since the 90° lead angle will have less tendency to follow the pre-existing hole.

AMOUNT OF STOCK REMOVAL

The maximum stock removal for rough boring may have to be decreased on very tough materials, extended overhangs as well as for extended slide blocks.

INSERT CORNER RADIUS

For heavy duty roughing applications the largest available corner radius should be selected unless otherwise specified. For finish boring with very little stock removal the smallest available corner radius is most advantageous to minimize lateral tool deflection. This can be especially important on applications involving long overhangs.

4 CUTTING EDGES PER INSERT

The 80° diamond shaped insert provides normally for two cutting edges. However, all four cutting edges can be used if a 75° and a 90° rough boring head within the same size range is utilized. The same is possible between a 75° rough boring head and a 90° finish boring head.

CUTTING DATA

Material	Finish boring (with single insert)				Rough boring (with double inserts)			
	Diameter	Cutting speed v_c	Feed f_z	Cutting depth a_p	Diameter	Cutting speed v_c	Feed f_z	Max. Cutting depth a_p max.
CARBON STEEL	6 - 30	110 - 140	0.05 - 0.15	0.05 - 0.30	24 - 30	110 - 140	0.15 - 0.25	4.2
	29 - 40	115 - 150			0.06 - 0.35	29 - 40	105 - 140	0.15 - 0.30
	39 - 50		0.10 - 0.20	0.07 - 0.50		39 - 50	105 - 150	0.20 - 0.30
	49 - 102				49 - 102	0.25 - 0.35		6.3
	100 - 220		100 - 220	0.30 - 0.40				
	220 - 500	220 - 500						
STEEL ALLOYS	6 - 30	100 - 130	0.05 - 0.15	0.05 - 0.30	24 - 30	90 - 120	0.15 - 0.25	
	29 - 40	110 - 140			0.06 - 0.35	29 - 40	100 - 130	0.15 - 0.30
	39 - 50	110 - 150	0.10 - 0.20	0.07 - 0.50		39 - 50		0.20 - 0.30
	49 - 102				49 - 102	0.25 - 0.35		6.3
	100 - 220		100 - 220	0.30 - 0.40				
	220 - 500		220 - 500					
STAINLESS STEEL	6 - 30	70 - 110	0.07 - 0.15	0.12 - 0.35	24 - 30	69 - 90	0.12 - 0.20	
	29 - 40	80 - 110			0.10 - 0.20	0.20 - 0.50	29 - 40	70 - 100
	39 - 50		0.12 - 0.20	0.25 - 0.75			39 - 50	
	49 - 102				49 - 102	0.25 - 0.35	6.3	
	100 - 220		100 - 220					
	220 - 500	220 - 500						
CAST IRON	6 - 30	70 - 110	0.07 - 0.15	0.12 - 0.35	24 - 30	60 - 110		0.20 - 0.30
	29 - 40	80 - 115			0.10 - 0.20		0.20 - 0.50	29 - 40
	39 - 50		0.12 - 0.20	0.25 - 0.75				39 - 50
	49 - 102				49 - 102		0.30 - 0.45	6.3
	100 - 220		100 - 220					
	220 - 500	220 - 500						
ALUMINIUM, ALUMINIUM ALLOYS	6 - 30	150 - 300	0.05 - 0.15	0.12 - 0.35	24 - 30	120 - 300	0.20 - 0.30	
	29 - 40	150 - 360	0.10 - 0.20	0.20 - 0.50	29 - 40	150 - 370	0.25 - 0.35	5.7
	39 - 50				0.10 - 0.25		0.25 - 0.75	
	49 - 102		49 - 102	0.30 - 0.45				6.3
	100 - 220		100 - 220	0.30 - 0.40				
	220 - 500	220 - 500						
TITANIUM	6 - 30	30 - 40	0.07 - 0.15	0.12 - 0.35	24 - 30	25 - 35	0.12 - 0.20	
	29 - 40	30 - 45			0.10 - 0.20	0.20 - 0.50	29 - 40	30 - 40
	39 - 50		0.25 - 0.75	0.20 - 0.35			39 - 50	
	49 - 102				49 - 102	0.20 - 0.35	6.3	
	100 - 220		100 - 220					
	220 - 500	220 - 500						
HARDENED ALLOYS	6 - 30	30 - 40	0.07 - 0.15	0.12 - 0.35	24 - 30	25 - 35		0.12 - 0.20
	29 - 40	30 - 45			0.10 - 0.20	0.20 - 0.50	29 - 40	30 - 40
	39 - 50		0.25 - 0.75	0.20 - 0.35			39 - 50	
	49 - 102				49 - 102	0.20 - 0.35	6.3	
	100 - 220		100 - 220					
	220 - 500	220 - 500						

EXAMPLES OF MACHINING

ROUGH BORING

THROUGH HOLE

Material: 42 Cr Mo 4
 Boring head: D 20075 300
 Arbor: BT 350 100 260
 Insert: TCMT 16T308
 Cutting speed: 120 m/min
 Cutting depth: 5 mm
 Feed: 0.25 mm/rev
 Boring depth: 200 mm
 Coolant

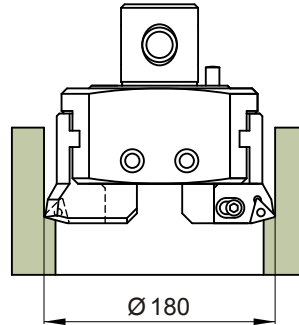

BLIND HOLE

Material: Ck 45
 Boring head: D 04290 402 N
 Arbor: BT 350 042 160
 Insert: CNMG 120408
 Cutting speed: 110 m/min
 Cutting depth: 3 mm
 Feed: 0.3 mm/rev
 Boring depth: 120 mm
 Coolant

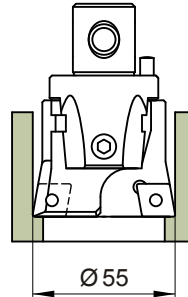

FINISH BORING

FINISH BORING SMALL DIAMETER

Material: Al Si 8 Cu 3
 Boring head: A 042 016 + S10/16 STF CR 09
 Arbor: BT 350 042 075
 Insert: TCMT 090202
 Cutting speed: 120 m/min
 Cutting depth: 0.2 mm
 Feed: 0.08 mm/rev
 Boring depth: 14 mm
 Coolant

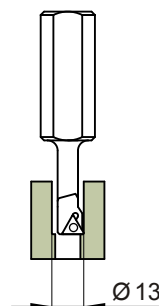

FINISH BORING

Material: St 37.3
 Boring head: A 03290 409
 Arbor: BT 350 032 130
 Insert: CCGT 09T304
 Cutting speed: 140 m/min
 Cutting depth: 0.2 mm
 Feed: 0.1 mm/rev
 Boring depth: 70 mm
 Coolant

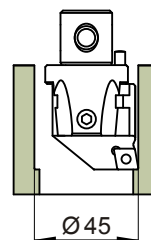

MODULAR BORING PROGRAM



www.pinzbohr.com

MAIN CATALOG

